

# *TI-Artist*

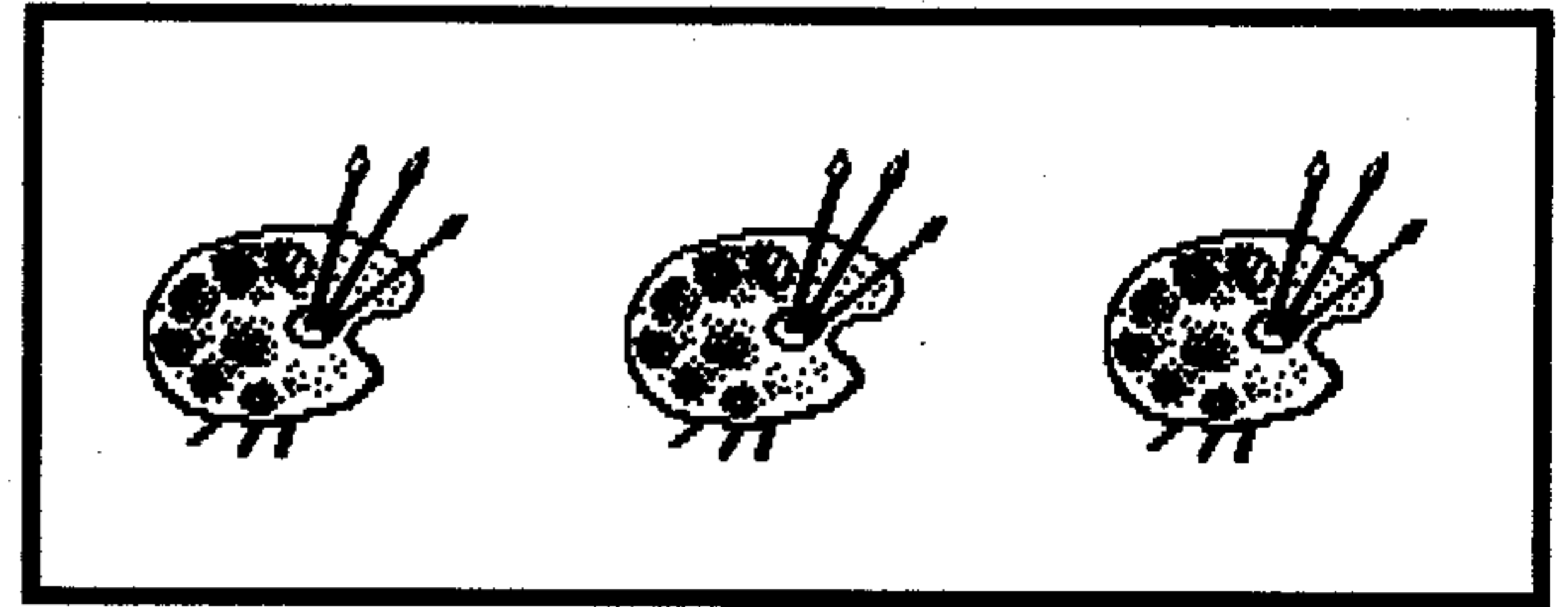

*for creating, editing, printing*

*graphics, drawings, artwork*

**INSCEBOT\***

P. O. BOX 250  
ARNOLD, MD 21018

*Copyright 1985 by Chris Faherty*

## TABLE OF CONTENTS

<b>TRYING IT OUT</b>	
Glossary .....	1
Introduction .....	1
Loading procedure .....	2
Valuable information .....	4
Additions and Changes .....	4
Extra Features .....	4
Using @NEWPATH .....	4
New Horizons Ramdisk Users .....	5
Myarc 128-512K Card Users .....	5
Myarc Hard Disc Users .....	5
Loading through Extended Basic .....	6
Loading through TI-Writer .....	6
Loading through Editor/Assembler .....	6
Putting TI-ARTIST to work .....	6
<b>I. TI-ARTIST</b>	
Draw .....	7
Point .....	7
Line .....	7
K-line .....	7
Rays .....	7
Fill .....	7
Frame .....	8
Box .....	8
Circle .....	8
Disc .....	8
Clear image .....	8
H or V .....	8
Swap .....	9
Invert .....	9
Alpha numeric .....	9
Clear color .....	9
Store .....	9
Zoom .....	10
Mirror .....	10
Hard Copy .....	10
Plot/Erase icon .....	10
Color cursor .....	10
Pattern indicator icon .....	10
Foreground/Background icon .....	11
Selecting the right color .....	11
<b>II. ENHANCEMENT</b>	
Move without color .....	12
Move with color .....	12
Copy without color .....	12
Copy with color .....	13
Slides and Instances .....	13
Alpha numeric entry .....	14
<b>III. INPUT DEVICE</b>	
What is an Input Device? .....	15
Customising .....	16
<b>IV. CONVERSIONS</b>	
Load picture .....	17
View picture .....	17
Save picture .....	17
<b>APPENDICES</b>	
A: Filename extensions (_C,_P,_F,_S,_I) .....	18
B: File setup - Instances .....	18
C: File setup - Character fonts .....	18
D: Indexing files .....	19

# KEY LAYOUT

## HORIZONTAL SIZE

Ctrl - [C] + [1] [2] [3] [4] [5] [6] [7] [8] [9]

## VERTICAL SIZE

Fctn - [F] + [1] [2] [3] [4] [5] [6] [7] [8] [9]

---

THESE REQUIRE FUNCTION KEY:

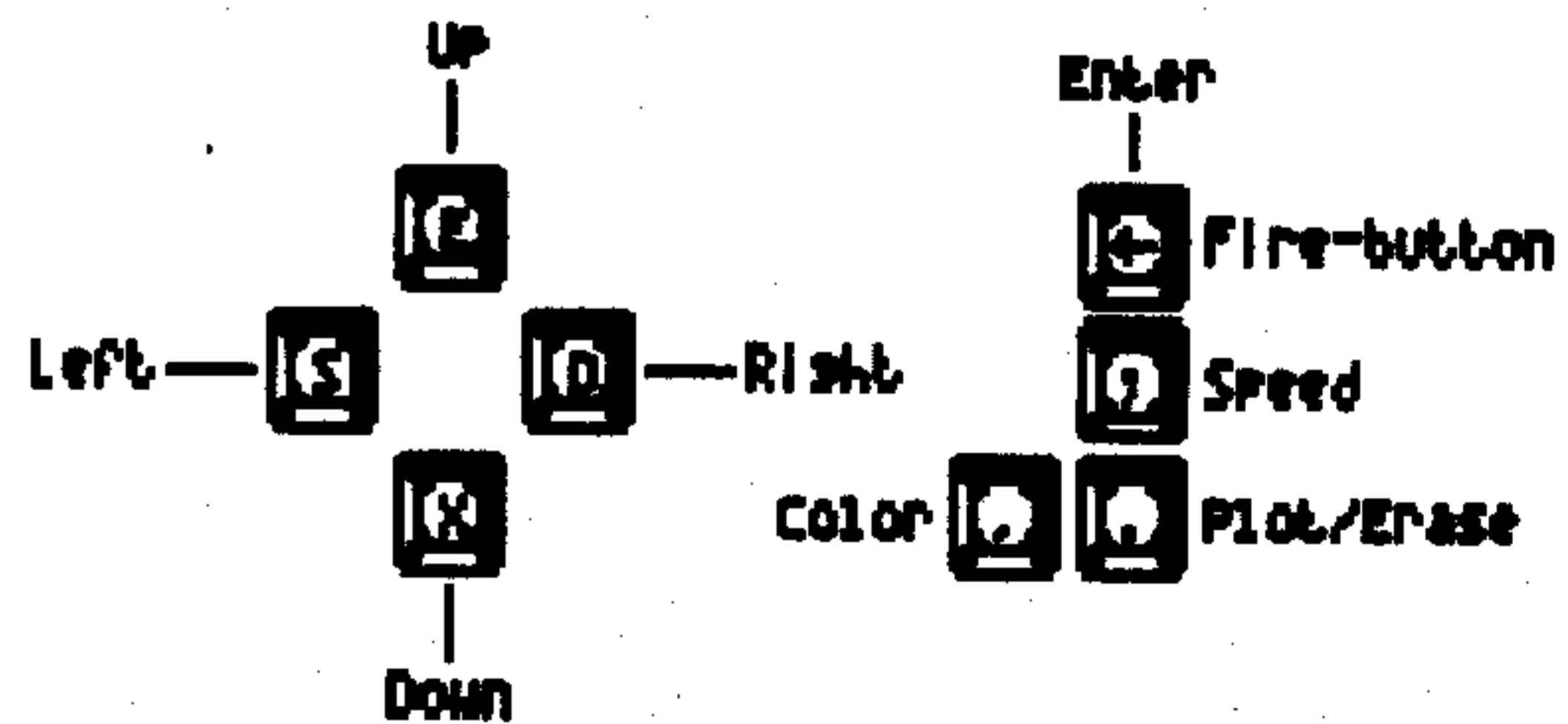

## TRYING IT OUT

### GLOSSARY

- Character Font** - A file that loads into the Enhancement to provide you with different sets of characters.
- Cursor** - An object on the screen used to indicate the current pen position.
- Density Factor (Hard Copy)** - Controls the pitch of the printout.
- Device Service Routine (DSR)** - A routine to handle communications between TI-Artist and a specific drawing utensil.
- External Reference** - A data word address that is to be used by several programs. The address is obtained by using a REF directive in the assembler.
- FCTN-"Quit"** - Used to return to main menu.
- Icon** - A picture on the menu used to select different functions.
- Instances** - A special feature that allows you to store portions of your picture on disk and combine them with other programs or other pictures.
- Line Spacing (Hard Copy)** - Determines how many 1/72" to skip for each line printed.
- Magnification Factor (Hard Copy)** - Controls the size of the printout.
- Pixel** - A picture element. A pixel is the smallest element of a picture that can be separately addressed.
- Plot** - The process of turning pixels "on".
- Styles** - A collection of 24 miniature designs that can be used as components in your picture.

### INTRODUCTION

TI-Artist is a generalized program which is intended to allow high quality graphics to be easily generated with minimal training. The intent is to provide a highly versatile graphics tool which is not only useful, but is also enjoyable and easy to use. With this in mind, the displays used to guide you through the drawing process have been designed to minimize the need to refer to any external documentation. Many built in functions have been provided to aid in the drawing process. Each of these functions is described in detail in the following sections. Additionally, TI-Artist permits easy access of input utensils to allow for future expansion.

Basically, TI-Artist presents the artist with a menu of functions. The desired function is selected by positioning the cursor over the desired icon and pressing the fire button. The drawing palette is then selected by depressing the space bar (subsequent depressions of the space bar will alternate between the functions menu and the drawing palette). Once on the drawing palette, the selected function may be performed. When a different function is desired, it may be selected by returning to the function menu or by depressing the desired function selector key.

Once the artist has completed a drawing, (or at any intermediate stopping point) the current palette may be saved on disk and/or displayed on a variety of printer types.

TI-Artist also provides a methodology of interfacing with a variety of current drawing program files to allow existing drawings to be fully utilized.

## LOADING PROCEDURE

### EDITOR/ASSEMBLER

1. Insert Editor/Assembler module.
2. Insert TI-Artist diskette into drive 1.
3. Press any key to display master selection list.
4. Select option for Editor/Assembler.
5. When you see the Editor/Assembler title screen, select option 5 for Run Program File.
6. At prompt, enter filename of DSK1.ARTIST1.
7. Press ENTER, program will be executed.

### MINI MEMORY

1. Insert MINI MEMORY module.
2. Insert TI-Artist diskette into drive 1.
3. Press any key to display master selection list.
4. Select option for MINI MEMORY.
5. When you see the MINI MEMORY title screen, select option 3 for Re-Initialize and press FCTN PROC'D.
6. Select option 1 for Load and Run.
7. At prompt, enter filename of DSK1.ARTIST1.
8. Press ENTER, program will be executed.

### EXTENDED BASIC

1. Insert EXTENDED BASIC module.
2. Insert TI-Artist diskette into drive 1.
3. Press any key to display master selection list.
4. Select option for EXTENDED BASIC.
5. Program will be executed.

### TI-WRITER

1. Insert TI-Writer module.
2. Insert TI-Artist diskette into drive 1.
3. Press any key to display master selection list.
4. Select option for TI-Writer.
5. Select option 3 for Utility.
6. At prompt, enter filename of DSK1.ARTIST1.
7. Press ENTER, program will be executed.

## CORCOMP MANAGER

1. Select option 1 for Disk Manager.
2. After the manager is loaded, insert TI-Artist diskette into drive 1.
3. Select option 1 for File Utilities.
4. Select option 2 for Load and Run Assembly File.
5. At prompt, enter drive number of 1.
6. At prompt, enter filename of ARTIST, press ENTER.
7. At prompt, enter program name of START.
8. Press ENTER, program will be executed.

## MYARC DISK CONTROLLER

1. Select TI Basic for TI Extended Basic.
2. Type CALL LR.
3. Type CALL LR("DSK1.ARTIST").

# REPLACEMENT POLICY

INSCEBOT INC. will replace, free of charge, any DEFECTIVE diskette within ninety (90) days of purchase date. After the warranty period expires, all replacements will require a fee of \$5.00 to accompany your original diskette.

Note: All replacements require that the original disk be sent to us.

INSCEBOT, INC.  
software  
P.O. Box 260  
Arnold, MD 21012

\* Editor/Assembler, Mini Memory, Extended Basic, TI-Writer, Corcomp, and Myarc are all trademarks of Texas Instruments Inc., Corcomp Inc., and Myarc Inc., respectively.

## VALUABLE INFORMATION

Here is some valuable information that you will need to know when using TI-Artist. To return to the main menu from any of the program sections, you must press FCTN-"Quit" while the program disk is either in drive 1 or if TI-Artist is installed on your ramdisk. The picture will be retained throughout any of the program sections (even if you do conversions).

When you are using the Hard Copy function, the devicename for your printer must have a .CRLF after it to suspend the carriage returns and line feeds from being sent to your printer automatically. As an example, let's say your printer is hooked up to your second serial port at 2400 baud. The devicename of RS232/2.BA=2400.DA=8.CRLF should be used within Hard Copy.

After you enter TI-Artist, you may want to experiment with icon selection. You can do this using two different methods, either: 1) position the cursor over the desired icon and press the fire button, or 2) type the corresponding letter of the desired icon using the keyboard. Please note that the second method may also be used while you are on the picture.

## ADDITIONS AND CHANGES

TI-Artist version 2.01 is now entirely file based, and can reside on nearly any mass storage peripheral. Now that TI-Artist is contained within a file hierarchy, it will allow convenient storage and backup of the program. In fact, it is recommended that you make at least one backup copy of your TI-Artist diskette and store it in a safe place. This can be accomplished using any disk manager such as the Disk Manager module supplied by Texas Instruments.

## EXTRA FEATURES

TI-Artist version 2.01 has a few extra features that were provided specifically for convenience and loading efficiency. As previously mentioned, TI-Artist version 2.01 is now completely file based. This means that the entire program is clearly visible with just a file listing of the diskette. The program may be easily copied onto any mass storage peripheral and executed at your leisure.

With the addition of a @NEWPATH program, TI-Artist may be configured and re-configured any number of times to be run from any device. For example, lets suppose that you wanted TI-Artist to load off of your Myarc ramdisk (128k card) instead of your disk drive. All that you would have to do is copy the files from your TI-Artist diskette onto your ramdisk, then use @NEWPATH to change the path to RD or any drive number that it is emulating.

By the way, due to popular demand another feature was implemented on this new version of TI-Artist. Within the Enhancement, users can now erase the pattern or color portions of your picture in the same way that you can in the TI-Artist section. Just press CTRL A to erase the pattern, or CTRL B to erase the color.

## USING @NEWPATH

The program named @NEWPATH on your TI-Artist version 2.01 diskette should be used to change the path name under which TI-Artist searches for its files. This is necessary to do whenever you move TI-Artist from one device to another (i.e. from disk to ramdisk).



To use the program, enter TI BASIC from the title screen and type OLD DSK1.@NEWPATH, then press enter. Type RUN, then press enter. The program will run and ask you several questions.

#### WHAT PERIPHERAL CONTAINS TI-ARTIST

] DSK1

The answer to this question is the devicename that the actual program is under right now. In the example, it was assumed that the TI-Artist diskette was in disk drive 1. Please note that TI-Artist can be copied onto any device, and the device that contains the TI-Artist that you wish to have re-pathed should be entered here.

#### THE CURRENT PATH USED WITH THIS TI-ARTIST IS:

] DSK.INSCEBOT

You are then told what the current path name is. In the example, the current path name was DSK.INSCEBOT. That happens to be the default when TI-Artist was first shipped to you.

#### NEW PATH FOR THIS TI-ARTIST (ENTER FOR NO CHANGE)

] RD

It then asks you what you would like the new path for TI-Artist to be. In the example, we used RD because that is what should be used for TI-Artist to be run off of the Myarc ramdisk (128k card).

#### NEW HORIZONS RAMDISK USERS

This new version will allow you to finally utilize your ramdisk with TI-Artist. The steps involved to install TI-Artist version 2.01 onto your new horizons ramdisk are as follows:

1. Copy all of the files onto your ramdisk using a disk manager file copy option.
2. Run @NEWPATH, and set the path name to DSK5 or DSK6.
3. That's it.

#### MYARC 128-512K CARD USERS

The steps involved to install TI-Artist version 2.01 onto your ramdisk are identical to the New Horizons except that the pathname can also be RD and cannot be DSK5. The RD pathname is recommended, though, because then you do not have to emulate (EMDK) your ramdisk to any drive number.

#### MYARC HARD DISC USERS

Those of you with hard disc systems can also benefit from this new version of TI-Artist. Once again, just copy the files onto your hard disc and run the @NEWPATH program to change the path.

#### LOADING THROUGH EXTENDED BASIC

TI-Artist version 2.01 always expects to be loaded off of DSK1 when using Extended Basic. Extended Basic searches for the LOAD program on DSK1, therefore, for convenience, the pathname is temporarily changed to DSK1.

#### LOADING THROUGH TI-WRITER

When TI-Artist version 2.01 is loaded via the TI-Writer utility option, the pathname used is always DSK.INSCEBOT. Therefore, if you wish to load TI-Artist version 2.01 off of your own diskettes or ramdisks through the TI-Writer utility option, be sure to name your disk INSCEBOT.

#### LOADING THROUGH EDITOR/ASSEMBLER

When TI-Artist version 2.01 is loaded via the Editor/Assembler option 5, the pathname used is always DSK.INSCEBOT. Therefore, if you wish to load TI-Artist version 2.01 off of your own diskettes or ramdisks through the Editor/Assembler option 5, be sure to name your disk INSCEBOT. If you would like TI-Artist to load using the pathname of your choice, just use option 3 (Load and Run) from the Editor/Assembler.

#### PUTTING TI-ARTIST TO WORK

Now that you have TI-Artist in your control, we may brainstorm and think of many uses for it. With the addition of the enhancement to TI-Artist, many more applications become within the range of your computer. It is true that Assembly Language programmers have the best means for using pictures, but many Extended Basic programmers will appreciate the "instances" that you may work with using TI-Artist. Using "instances", you are able to easily incorporate portions of your picture within your own programs. In fact, you may even use TI-Artist to generate sprite patterns or title screens.

# I. TI-ARTIST

This section of the manual pertains to the use of the TI-ARTIST portion of the package. To select any of the functions within TI-ARTIST, you must either position the cursor over the desired icon and press the fire button, or press the appropriate letter on the keyboard. To switch between the menu and your picture, press the space bar.

## DRAW

The draw function lets you draw designs on your picture. To use the draw function, simply position the cursor over the desired pixel and press the fire button. A trail will be drawn as long as the fire button is depressed. By changing the brush styles, you can draw some interesting and unique shapes. By changing the state of the plot/erase icon, the draw function will also let you erase.

## POINT

The point function is very similar to the draw function with one minor difference. When using the point function it will only plot one pixel at a time. In every other aspect, the point function is the same as the draw function.

## LINE

The line function will let you plot individual lines on your picture. To draw a line, you must designate the endpoints of the line. To do this, simply move the cursor to one of the desired endpoints and press the fire button. After the first endpoint is set, you will see a "rubber band" line. Just move the line until it touches the second desired endpoint and press the fire button.

## K-LINE

The k-line function is very similar to the line function with one minor difference. When using the k-line function, it will let you draw a continuous line by using the previous line endpoint as the current k-line endpoint. Other than that difference, the k-line function is the same as the line function.

## RAYS

The rays function is similar to the line function with two minor differences. First, when using the rays function, all of the lines drawn will be from the same origin. Second, the fire button only needs to be pressed (and held) once to create multiple rays. Aside from those differences, the rays function is the same as the line function.

## FILL

The fill function is used to fill a shape with a desired pattern. The fill function used in TI-ARTIST is a "smart fill". This means that it will look for openings and fill the entire shape regardless of where you start the fill. To use the fill function, position the cursor over the desired starting position and press the fire button.

Note: At any time during the fill you may abort by pressing the space bar.

## FRAME

The frame function is used to draw individual rectangles on your picture, or to frame objects on the screen. To use the frame routine, you must first designate where you want a corner of the frame to appear and press the fire button. You will then see a "rubber band" frame on the screen. By moving an imaginary point around the screen, you can vary the size of the frame. When the frame is of the correct shape and size, press the fire button.

## BOX

The box function is very similar to the frame function with one difference. When using the box function, after the box is drawn it will fill it in with the specified pattern. Aside from that difference, the box function is the same as the frame function.

Note: When the pattern is set to "P", and the plot/erase icon is off, the box function makes an exceptional "block eraser".

## CIRCLE

The circle function is used to draw individual circles on your picture. To use the circle function, you must first designate the center point of the circle. To do this, position the cursor over the desired center point and press the fire button. Then, by means of an imaginary point, you may vary the radius of the "rubber band" circle. When it is the desired size, press the fire button.

## DISC

The disc function is very similar to the circle function with one difference. When using the disc function, after the disc is drawn it will fill it in with the specified pattern. Aside from that difference, the disc function is the same as the circle function.

Note: When the pattern is set to "P", and the plot/erase icon is off, the disc function makes an exceptional "block eraser".

## CLEAR IMAGE

Your picture actually consists of two tables stored in memory: the pattern table (called "Image" in TI-ARTIST) and the color table. The pattern table contains all of the pixels of your screen and the color table contains the colors of these pixels. The clear image function is used to clear only the pattern portion of your picture, leaving the color portion untouched.

Note: To clear your entire picture you must both Clear image and Clear color. When you are in the zoom mode, this function also works relative to your window.

## H OR V

The H or V function is used to draw individual horizontal or vertical lines on your picture. To use the H or V function, you must first designate one of the endpoints of the lines. To do this position the cursor over the desired endpoint and press the fire button. You may then move an imaginary point horizontally or vertically to change the length of the "rubber band" line. When it is the desired length, press the fire button.

Note: The main usage of this function becomes apparent when you are using an analog device (such as a mouse) rather than a joystick. Analog devices are generally more difficult to draw straight lines with than a joystick.

### SWAP

The swap function is used to swap colors around on your picture. To use the swap function, you must first set the cursor to the color that you wish to become the new color. Then you must position the cursor on a patch of color that you wish to swap with the new color on your picture. When you are sure of this decision, press the fire button. All occurrences of that color will be swapped with the new color.

Note: When you are in the zoom mode, this function also works relative to your window.

### INVERT

The invert function is used to invert all of the pixels of your picture. This function is very handy when you wish to obtain an inverted hard copy, or just to see what it looks like.

Note: When you are in the zoom mode, this function also works relative to your window.

### ALPHA NUMERIC

The alpha numeric function is used to type variable sized letters on your picture. The letters may be in any one of 81 different sizes. To select the horizontal size of the letters press keys "CTRL-1" through "CTRL-9". To select the vertical size of the letters press keys "FCTN-1" through "FCTN-9". To use the alpha numeric function, you must first designate where on the screen you wish to start typing. To do this, position the cursor over the desired starting position and press the fire button. The cursor will then disappear, and allow you to type in whatever you wish. To exit the alpha num function you must press the fire button again.

Note: Do not confuse this function with the alpha numeric entry found in the Enhancement.

### CLEAR COLOR

Your picture actually consists of two tables stored in memory: the pattern table (called "Image" in TI-ARTIST) and the color table. The pattern table contains all of the pixels of your screen and the color table contains the colors of these pixels. The clear color function is used to clear only the color portion of your picture, leaving the pattern portion untouched.

Note: To clear your entire picture you must both Clear color and Clear image. When you are in the zoom mode, this function also works relative to your window.

### STORE

When the store function is selected, a store menu will appear on the screen. From this menu you may load pictures, save pictures, or index the pictures on a diskette.

Note: When you are in the zoom mode, the saved picture will be ONLY the portion within the zoom window.

### ZOOM

The zoom function is used to magnify a portion of your picture for detailed work. When the zoom function is selected, an 8 x 6 character frame will appear on the screen. The area inside of the frame will be magnified when you press the fire button. This process takes several seconds, so please be patient. Unlike other drawing programs, once magnified, you may use any of the other functions.

Note: The zoom mode is extremely useful in making zoomed-in hard copies. When you save a picture in this mode, only the zoomed in portion will be saved. If you wish to save the entire picture, cancel the zoom mode before saving your picture.

### MIRROR

When the mirror function is selected, every function that you use will result in four reflections of the design being placed on the screen. This function is fun to use and can produce very amusing effects.

Note: When you are in the zoom mode, this function also works relative to your window.

### HARD COPY

When the hard copy function is selected, a hard copy menu will appear on the screen. From this menu you may select the type of printer that you have. After you select your printer type, you must enter the device name to access your printer. You will then be asked for printing parameters (number of parameters varies between printers). The density factor determines the pitch of the printout. The magnification factor determines how large the printout will be. The line spacing determines how many 1/72" to skip for each line printed.

Note: When you are in the zoom mode, this function also works relative to your window.

### PLOT/ERASE ICON

The plot/erase icon is used to set the state of the pixels used in all of the functions. If it is highlighted, then all of the functions will work by plotting pixels. If it is off, then all of the functions will work by erasing pixels. This icon may also be toggled by pressing "FCTN-".

### COLOR CURSOR

The color cursor is used to modify only the color portion of your picture. It moves on the color boundaries set by bit-map mode, so that you may accurately place colors.

### PATTERN INDICATOR ICON

The pattern indicator icon is used to select one of 10 patterns (plus normal) that will be used in the fill box or disc. When this icon is displaying a "P" it is in the normal mode, in which the pattern is completely filled in.

Note: When the plot/erase icon is off, all of the patterns will be inverted. Therefore, when the pattern is displaying a "P", the disc, and box functions will act as block erasers.



## FOREGROUND/BACKGROUND ICON

The foreground/background icon is used before selecting colors, it tells whether to use the color as foreground, or background. The background color is indicated by a small square in the upper-left corner of the cursor.

## SELECTING THE RIGHT COLOR

To select different colors, simply position the cursor over one of the color samples at the bottom of the screen and press the fire button. The color will be used as either the foreground or background depending on the state of the Foreground/Background icon. You may also change the foreground color by pressing "FCTN-". This will scroll through all of the available colors.

## **II . ENHANCEMENT**

This section of the manual pertains to the use of the ENHANCEMENT portion of the package. To select any of the functions within the ENHANCEMENT, you must either position the cursor over the desired icon and press the fire button, or press the appropriate letter on the keyboard. To switch between the menu and your picture, press the space bar.

### MOVE WITHOUT COLOR

The move without color function is used to move a selected portion of your picture. To use this function, you must first designate one of the corners of the move area. To do this, position the cursor over the desired pixel and then press the fire button. You will then see a "rubber band" box appear on the screen. You must then expand the box to surround the area that you wish to move. When you press the fire button again, the area that you surrounded will be "picked up". You may now move the box around to the area that you wish to drop the surrounded area. You may see what it will look like by pressing "T" on the keyboard. When you are satisfied with its position, press the fire button and it will be dropped.

Note: When you first surround the area to be moved, the corner that you start with will automatically become the upper-left corner of the dropped image. Keeping this in mind, you may horizontally or vertically flip the surrounded image if you desire mirrored images.

### MOVE WITH COLOR

The move with color function is very similar to the move without color function with one difference. When using the move with color, the cursor will move along the color boundaries set in bit-map mode. Other than that difference, the move with color function is the same as the move without color function.

### COPY WITHOUT COLOR

The copy without color function is used to copy a selected portion of your picture. To use this function, you must first designate one of the corners of the copy area. To do this, position the cursor over the desired pixel and then press the fire button. You will then see a "rubber band" box appear on the screen. You must then expand the box to surround the area that you wish to copy. When you press the fire button again, the area that you surrounded will be "picked up". You may now move the box to the area where you wish to drop the surrounded area. You may see what it will look like by pressing "T" on the keyboard. When you are satisfied with its position, press the fire button and it will be dropped.

Note: When you first surround the area to be copied, the corner that you start with will automatically become the upper-left corner of the dropped image. Keeping this in mind, you may horizontally or vertically flip the surrounded image if you desire mirrored images.

## COPY WITH COLOR

The copy with color function is very similar to the copy without color function with one difference. When using the copy with color, the cursor will move along the color boundaries set in bit-map mode. Other than that difference, the copy with color function is the same as the copy without color function.

## SLIDES

Slides are a collection of 24 miniature designs that can be used as components in your picture. You may independently define, erase, or rotate them as you see fit. The enhancement boots-up with a slide set of electronic symbols as an example of their usefulness.

To select any of the slides, just position the cursor over the desired slide on the menu and press the fire button. You may then move the slide around and press the fire button when you wish to drop it. Exit by pressing the space bar.

When the slides function is selected, a slides menu will appear on the screen. From this menu, you may define slides, erase slides, rotate slides, load slide files, save slide files, load instances, or save instances.

Instances are sections of larger pictures that may be used within other pictures or in your own programs. Instances were implemented within the enhancement to provide you with a simple means of transporting portions of your pictures into a readily acceptable form for other uses. For example, how many times have you wanted to design a logo or emblem in a drawing program and incorporate it into your own program? Now that is entirely possible. Not only do instances let you do that, but they allow you to design your own character fonts, icons, and many more things. The file type that instances use is directly readable by many of your word processors, editors, and the assembler. They are saved in a DIS/VAR 80 file using decimal numbers separated by commas. Since instances are saved on character boundaries, the data in these files are character definitions.

Note: When you first surround the area to be used as an instance, the corner that you start with will automatically become the upper-left corner of the saved instance. This allows you to horizontally or vertically flip the saved instance.

### Steps involved after selection from SLIDES menu:

Define slides - 1) position the cursor over the slide box that you wish to define, press the fire button. 2) use the box to surround the area to become a slide, press the fire button.

Erase slides - 1) position the cursor over the slide box that you wish to erase, press the fire button.

Rotate slides - 1) position the cursor over the slide box that you wish to rotate, press the fire button.

Load slides file - 1) enter the filename of the slides file that you wish to load, press enter.

Save slides file - 1) enter the filename that you wish to save the current slides under.

Load an instance - 1) enter the filename of the instance file that you wish to load, press enter. 2) position the box at the desired location and press "T" to test, or enter to permanently drop.

Save an instance - 1) enter the filename that you wish to save the instance under, press enter. 2) position the cursor over one of the corners of the instance. 3) expand the box to surround the instance that you wish to save. 4) press the fire button when you are ready to save the instance.

## ALPHA NUMERIC ENTRY

When the alpha numeric entry function is selected, an alpha numeric entry menu will appear on the screen. From this menu, you may load character fonts, or type text on the screen.

To type text on the screen, you must first load the desired character font. After you load the character font, you may then select "(2) type text on screen." You must then enter the text string into the line buffer at the bottom of the screen. When you press enter, a box will appear, centered on the screen, that has the same size that the text will occupy in your selected character font. You may move this box around the screen and press "T" to test and see what it will look like. When you are satisfied with its position, press enter. You may then re-use the same string, or press the space bar to return to the menu.

## III. INPUT DEVICE

### WHAT IS AN INPUT DEVICE?

An input device is generally a drawing utensil. Whether it be the joystick, mouse, touch tablet, or a space tablet, they all require a Device Service Routine (DSR) to interface them to TI-ARTIST.

You may have noticed that this feature is very unique to TI-ARTIST, and it is a very powerful feature to have. No longer will you have to settle for the inaccuracy of the joystick, but you may now use any input device that you wish. Several DSR's, to be released by Inscobot, Inc., will allow you to hook up very diverse drawing utensils to TI-ARTIST.

If you wish, you may write your own input device DSR's. Different from earlier versions of TI-ARTIST, version 2.01 has a full object code loader for these DSR's. Listed below are a few rules that must be followed when you are writing your own input device DSR's:

- 1) The program must be assembled in compressed object code.
- 2) The program must be assembled in relocatable form.
- 3) To access internal information from TI-ARTIST, the DSR program should Externally Reference certain data words. Below is a list of them:

<u>LABEL</u>	<u>FUNCTION</u>
ZOOM	tells whether or not zoom mode is on
ZOOM2	tells whether or not to ignore zoom
A	X location 1
B	Y location 1
C	X location 2
D	Y location 2
E	X location 3
F	Y location 3
G	X location 4
H	Y location 4
MNA	X location 5
MNB	Y location 5
WNA	X location 6
WNB	Y location 6
XMIN	minimum acceptable X location
XMAX	maximum acceptable X location
YMIN	minimum acceptable Y location
YMAX	maximum acceptable Y location
FIRE	tells whether or not fire button has been pressed
SPACE	tells whether or not space bar has been pressed
DELAY	tells whether or not to delay for fast speed
DELAY2	tells whether or not to delay for slow speed
DELCNT	delay count for fast speed
DELCN2	extra delay count for slow speed
CTABLE	address of color table in CPU memory
PTABLE	address of pattern table in CPU memory

Data words that are used as indicators have two states. If they are true, then all the bits are on (>FFFF), and if they are false, then all of the bits are off (>0000).

The data words for X and Y locations must be accessed using R15 as an index register and using A and B as the base address. Therefore, any references for X and Y locations should be @A(R15) and @B(R15). Furthermore, R14 is used to tell whether or not to use a status test on the fire button. If true, the fire button may only be pressed once, if false, the fire button may be held down.

### CUSTOMISING

You can customise your TI-ARTIST diskette to power-up with your favorite input device DSR. To do this, just copy your DSR onto your TI-ARTIST diskette and name it EXTDSR. Before you do this, please make sure that you save the original EXTDSR onto another disk, otherwise you may loose the joystick DSR.



**Example:**

C	(ASCII character)
2,1,12	(2 characters wide, 1 character high, and skip 12 pixels)
1,1,1,1,1,1,1,1	
2,2,2,2,2,2,2,2	
D	(need ASCII character to define)
1,2,11	(1 character wide, 2 characters high, and skip 11 pixels)
1,1,1,1,1,1,1,1	
2,2,2,2,2,2,2,2	

**INDEXING FILES**

On the main menu there is an option that allows you to index all of the special files that pertain to the Enhancement. They include Fonts, Slides, and Instances. While the index is in progress, you may press and hold any key down to pause the listing. When the listing is complete, press enter.