

Service Manual

Color Video Monitor

CT-110MA/CT-110MCA

Chassis

No. NMX-K6NA (CT-110MA)
No. NMX-K6NB (CT-110MCA)

Main Manual

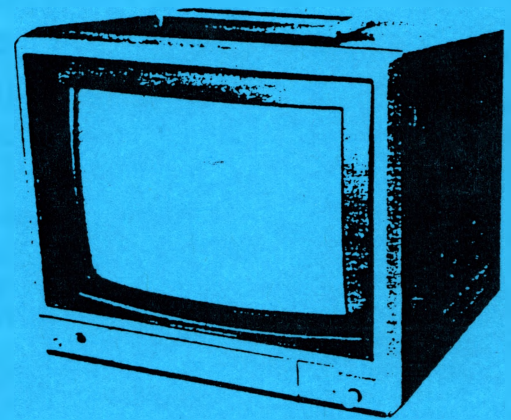

The service technician is required to read and follow the "Safety Precautions" and "Important Safety Notice" in this service manual.

Specifications

Power Input:	120 volts, 50/60 Hz, AC	Speaker:	3 inches Round Type 16 Ω , voice Coil
Power Consumption:	58 watts average 0.9 amperes max.	Automatic Circuits:	Automatic Frequency and Phase Control Horizontal Automatic Frequency Control Automatic degaussing Automatic Voltage Regulator Automatic Beam Limiter Automatic Color Control
Video Input (Bridging):	1.0Vp-p \pm 10% High or 75 Ω switchable BNC type bridging and 8-pin connectors	Picture Tube:	290KB22 52 Square inches 10 inches measured diagonally 90° deflection Quintrix II, In-Line
Audio Input (Bridging):	RCA type bridging and 8-pin connectors	Dimensions:	Height: 10- $\frac{3}{4}$ inches (275 mm) Width: 11- $\frac{3}{4}$ inches (297 mm) Depth: 12- $\frac{3}{4}$ inches (323 mm)
Semiconductors:	20 transistors 27 diodes 1 posistor	Weight:	22 lbs. (10.0 kg)
Integrated Circuits:	2		
Anode Voltage:	24.0 kV \pm 1 kV (at zero beam current)		
Sound Output:	0.9 watts (10% distortion) Maximum 1.2 watts		

Panasonic.

Specifications are subject to change without notice.

Panasonic Company
Division of Matsushita Electric
Corporation of America
One Panasonic Way, Secaucus,
New Jersey 07094

Panasonic Hawaii, Inc.
91-238 Kauhū St. Ewa Beach
P.O. Box 774
Honolulu, Hawaii 96808-0774

Panasonic Canada
Division of Matsushita Electric
of Canada Limited
5770 Ambler Drive, Mississauga,
Ontario, Canada, L4W 2T3

Panasonic Sales Company,
Division of Matsushita Electric
of Puerto Rico, Inc.
Ave. 65 De Infantería, KM 9.7
Victoria Industrial Park
Carolina, Puerto Rico 00630

Service Manual

Color Video Monitor
CT-110MA/CT-110MCA

Chassis

No. NMX-K6NA (CT-110MA)
No. NMX-K6NB (CT-110MCA)

Main Manual

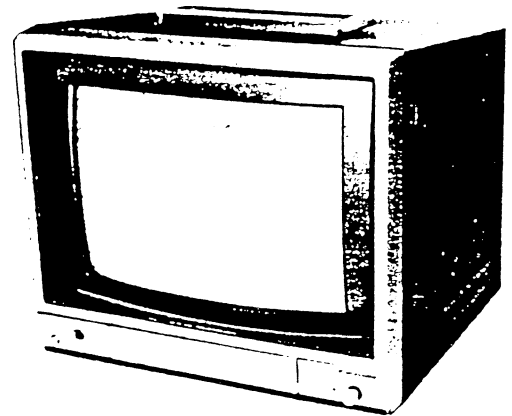

The service technician is required to read and follow the "Safety Precautions" and "Important Safety Notice" in this service manual.

Specifications

Power Input:	120 volts, 50/60 Hz, AC	Speaker:	3 inches Round Type 16 Ω , voice Coil
Power Consumption:	58 watts average 0.9 amperes max.	Automatic Circuits:	Automatic Frequency and Phase Control Horizontal Automatic Frequency Control
Video Input (Bridging):	1.0Vp-p \pm 10% High or 75 Ω switchable BNC type bridging and 8-pin connectors	Picture Tube:	Automatic degaussing Automatic Voltage Regulator Automatic Beam Limiter Automatic Color Control 290KB22 52 Square inches 10 inches measured diagonally 90° deflection Quinrix II, In-Line
Audio Input (Bridging):	RCA type bridging and 8-pin connectors	Dimensions:	Height: 10- $\frac{3}{4}$ inches (275 mm) Width: 11- $\frac{3}{4}$ inches (297 mm) Depth: 12- $\frac{3}{4}$ inches (323 mm)
Semiconductors:	20 transistors 27 diodes 1 posistor	Weight:	22 lbs. (10.0 kg)
Integrated Circuits:	2		
Anode Voltage:	24.0 kV \pm 1 kV (at zero beam current)		
Sound Output:	0.9 watts (10% distortion) Maximum 1.2 watts		

Panasonic.

Specifications are subject to change without notice.

Panasonic Company
Division of Matsushita Electric
Corporation of America
One Panasonic Way, Secaucus,
New Jersey 07094

Panasonic Hawaii, Inc.
91-238 Kauni St. Ewa Beach
P.O. Box 774
Honolulu, Hawaii 96808-0774

Panasonic Canada
Division of Matsushita Electric
of Canada Limited
5770 Ambler Drive, Mississauga,
Ontario, Canada, L4W 2T3

Panasonic Sales Company,
Division of Matsushita Electric
of Puerto Rico, Inc.
Ave. 65 De Infanteria, KM 9.7
Victoria Industrial Park
Carolina, Puerto Rico 00630

CONTENTS

SAFETY PRECAUTIONS	2
DISASSEMBLY INSTRUCTIONS	4
GENERAL CONNECTION & APPLICATIONS	5
FIELD ALIGNMENT	7
GENERAL ALIGNMENT	9
CIRCUIT EXPLANATION	9
CONDUCTOR VIEWS	9
SCHEMATIC DIAGRAM	11
EXPLODED VIEWS	12
REPLACEMENT PARTS LIST	13

THIS MODEL COMPLIES WITH DHHS RULES 21 CFR SUBCHAPTER J APPLICABLE AT DATE OF MANUFACTURE.

IMPORTANT SAFETY NOTICE

There are special components used in Panasonic Video Monitor set which are important for safety. These parts are shaded on the schematic diagram and on the replacement parts list. It is essential that these critical parts should be replaced with manufacturer's specified parts to prevent X-RADIATION, shock, fire, or other hazards. Do not modify the original design without permission of Matsushita Electric.

ABBREVIATIONS USED IN THIS MANUAL

ABL	Automatic Beam Limiter	AVR	Automatic Voltage Regulator
APC	Automatic Phase Control	CRT	Cathode Ray Tube
DY	Deflection Yoke	FBT	Flyback Transformer
OTL	Transformerless Output	HAFC	Horizontal Automatic Frequency Control
SEPP	Single Ended Push-Pull Circuit	SCS	Silicon-Controlled Switch
ACC	Automatic Color Control	VCO	Voltage-Controlled Oscillator

SAFETY PRECAUTIONS

GENERAL GUIDELINES

1. It is advisable to insert an isolation transformer in the power line and AC supply before servicing a hot chassis.
2. When servicing, observe the original lead dress; especially the lead dress in the high voltage circuits. If a short circuit is found, replace all parts which have been overheated or damaged by the short circuit.
3. After servicing, see to it that all the protective devices such as insulation barriers, insulation papers, shields, and isolation R-C combinations, are properly installed.
4. Before turning the monitor on, measure the resistance between B+ line and chassis ground. Connect \ominus side of an ohmmeter to the B+ lines, and \oplus side to chassis ground. Each line should have more resistance than specified, as follows:

B+ Line	Minimum Resistance
116V	25k Ω
24V	200 Ω
12V	150 Ω
5. When the monitor is not to be used for a long period of time, unplug the power cord from the AC outlet.
6. Potentials, as high as 24.0 kV are present when this monitor is in operation. Operation of the monitor without the rear cover involves the danger of a shock hazard from the monitor power supply. Servicing should not be attempted by anyone who is not thoroughly familiar with the precautions necessary when working on high-voltage equipment. Always discharge the anode of the picture tube to the monitor chassis before handling the tube.
7. After servicing, make the following leakage current checks to prevent the customer from being exposed to shock hazards.

LEAKAGE CURRENT COLD CHECK (See figure 1.)

1. Unplug the AC cord and connect a jumper between the two prongs on the plug.
2. Turn on the monitor's power switch.
3. Measure the resistance value, with an ohmmeter, between the jumpered AC plug and each exposed metallic cabinet part on the monitor, such as screw-heads, antennas, control shafts, handle bracket, etc.

When the exposed metallic part has a return path to the chassis, the reading should be between 240 kΩ and 5.2 MΩ.

When the exposed metal does not have a return path to the chassis, the reading must be ∞.

LEAKAGE CURRENT HOT CHECK (See Figure 1.)

1. Plug the AC cord directly into the AC outlet. Do not use an isolation transformer for this check.
2. Connect a 1.5 kΩ, 10 watts resistor, in parallel with a 0.15 μF capacitor, between each exposed metallic part on the set and a good earth ground such as a water pipe, as shown in figure 1.
3. Use an AC voltmeter, with 1000 ohms/volt or more sensitivity, to measure the potential across the resistor.
4. Check each exposed metallic part, and measure the voltage at each point.
5. Reverse the AC plug in the AC outlet and repeat each of the above measurements.
6. The potential at any point should not exceed 0.75 volts RMS. A leakage current tester (Simpson Model 229 or equivalent) may be used to make the hot checks, leakage current must not exceed 1/2 milliamp. In case a measurement is out side of the limits specified, there is a possibility of a shock hazard, and the monitor should be repaired and rechecked before it is returned to the customer.

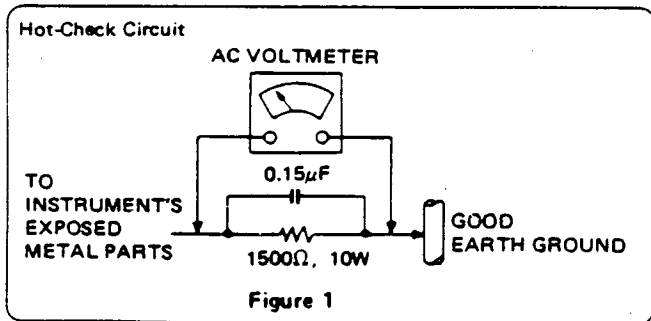

Figure 1

X-RADIATION

WARNING: 1. The potential source of X-Radiation in TV sets is the High Voltage section and the picture tube.

2. When using a picture tube test jig for service, make sure the jig is capable of handling 25.0 kV without causing X-Radiation.

NOTE: It is important to use an accurate, periodically calibrated high voltage meter.

1. Turn the Bright and the Panabrite controls fully counter-clockwise.
2. Set the SERVICE switch to SERVICE.
3. Measure the High Voltage. The upper meter (electrostatic type) reading should indicate 24 kV ± 1.0 kV. If the upper meter indication is out of tolerance, immediate service and correction is required to prevent the possibility of premature component failure.
4. To prevent an X-Radiation possibility, it is essential to use the specified picture tube.
5. To prevent exposure to X-Radiation, the picture tube shield must be kept in place with power applied to the set.

HORIZONTAL OSC. DISABLE CIRCUIT TEST

SERVICE WARNING: This test must be made as a final check before the set is returned to the customer.

1. With rear cover removed, supply nominal 120 V AC to the set and turn on the power switch.
2. Adjust the customer controls to normal position.
3. Short the collector and the emitter of Q801 with a jumper wire. Confirm that the picture tube screen blacks out (horizontal oscillation stops).
4. If this does not occur, the Horizontal OSC. Disable Circuit is not operating. Follow the Horizontal Oscillator Disable Circuit Repair Procedures before the set is returned to customer.

HORIZONTAL OSC. DISABLE CIRCUIT REPAIR PROCEDURE

- 1) Connect a DC voltmeter between the cathode of D504 and chassis ground of the main circuit board. If nearly 20 V is not present on the cathode, find the cause. Check R527, D504 and C519.
- 2) Connect a DC voltmeter between the cathode of D505 and chassis ground of the main circuit board. If nearly 11.0 V is not present on the cathode, find the cause. Check R518, R519 and D506.
- 3) Repeat step 2) procedure. If nearly 11.0 V is present on the cathode, check IC401, R520, C525 and D505.
- 4) Carefully check above specified parts, and related circuits and parts. When the circuit is repaired, try the horizontal oscillator disable circuit test again.

DISASSEMBLY INSTRUCTIONS

BACK CABINET REMOVAL

1. Remove 7 (A) screws shown in figure 2.
2. Pull the cabinet toward you.

TOP CABINET REMOVAL

1. Remove OFF-ON Volume knob on the front panel and place the set with the picture tube face down.
2. Remove 8 (B) screws and then carefully pull the top panel upward as shown in figure 3.

SPEAKER BLOCK REMOVAL

1. Disconnect a coupler (C) and remove 5 (D) screws shown in figure 4.
2. Pull off the speaker block from the chassis bracket.

CHASSIS REMOVAL

1. Disconnect C-Board and anode lead from CRT, 6 couplers from A-Board, 1P lug terminal from chassis bracket and 1P connector from C-Board.
2. Then slowly slide the chassis backward and remove from the rails.

CRT REMOVAL

1. Remove 4 (E) screws and remove CRT off as shown in figure 5.

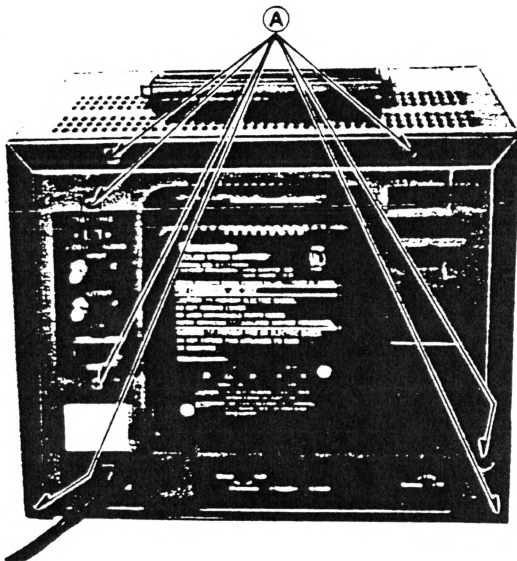

Figure 2

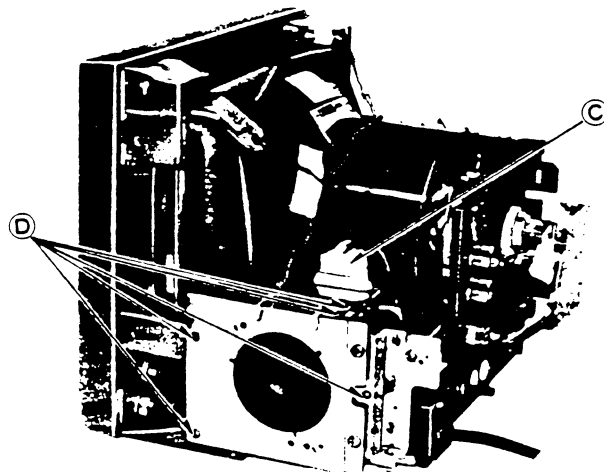

Figure 4

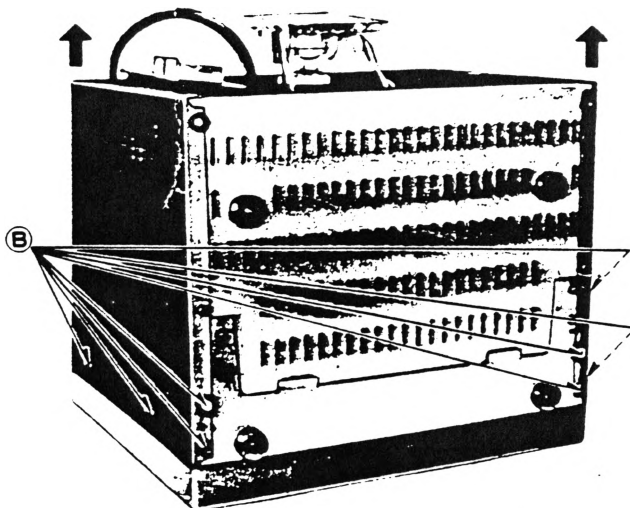

Figure 3

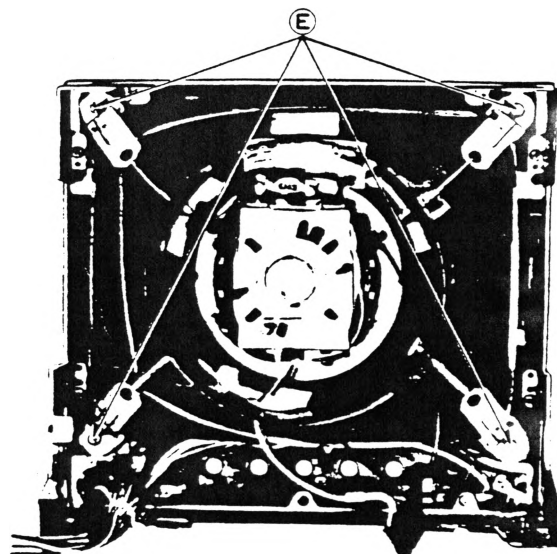
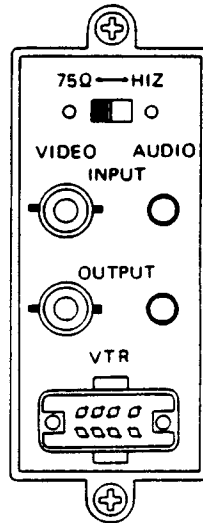

Figure 5

GENERAL CONNECTION & APPLICATIONS

[Video/Audio Terminals]



Signal level and Terminal impedance

Terminal \ Item		Level	Impedance	Remarks
VIDEO	INPUT	1Vp-p	75Ω/HIZ	Video Signal includes Sync. Signal
	OUTPUT	1Vp-p	75Ω/HIZ	
AUDIO	INPUT	0 dB	10 kΩ	1V rms = 0 dB 400 Hz
	OUTPUT	0 dB	10 kΩ	
AUDIO/VIDEO	VTR	1Vp-p	75Ω	Video and Audio Signal
		0 dB	20 kΩ	

[75Ω-HIZ Switch]

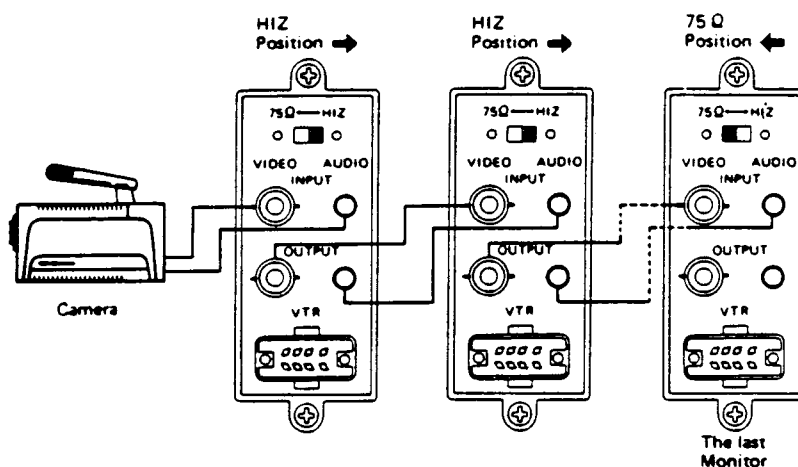

[Application with other equipment]

Terminal	VTR/LINE Selector Position	Signal	Equipment	Remarks
INPUT	LINE	Line-in Signal from other equipment	VTR/Video Camera	Line-in and line-out connectors are bridged. (connected in parallel)
OUTPUT	LINE	Line-in Signal	Monitor or VTR	When this connector is not used, then termination select switch should be set to 75 ohms position. When another monitor's line-in is connected to this monitor's line-out connector, the termination select switch should be set to HIZ position. The last monitor in the series of monitors should then have it's switch set to 75 ohms.
VTR (8-pins)	VTR	Video/Audio Signal in/out from/to VTR	½ inch VTR, ½, ¾ inch VCR and VHS VCR	

[Connectors]

Video Input (Bridging) : More than 1.0Vp-p, High impedance or 75Ω switchable, BNC-type bridging and 8-pin connectors.

Audio Input (Bridging) : RCA-type and 8-pin connectors

Video/Audio Output : BNC-type video and RCA-type audio connectors.

FIELD ALIGNMENT OF VIDEO MONITOR

Note: Use Video pattern Generator for following alignments. (Video input should read 1.0Vp-p)

A. WITHOUT TEST EQUIPMENT

Alignment can be accomplished by general procedures. The following describes simple alignment methods that do not require extensive service shop test equipment.

VERTICAL HEIGHT ADJUSTMENT

Adjust Vertical Height control (R402) until the picture or test pattern is symmetrical from top to bottom.

COLOR PURITY ADJUSTMENT

(See figure 6, 7, 8 and 10.)

1. Operate the monitor for 20 minutes, with the Bright control at maximum to warm up the CRT.
2. Degauss the monitor fully by using an external degaussing coil.
3. Roughly adjust the convergence. (See page 8.)
4. Apply black and white pattern.
5. Turn the Red and Blue Cut-Off controls fully counterclockwise to obtain a green field. Adjust the R. Drive controls if the green field cannot be obtained.
6. Loosen the deflection yoke clamp screw and move the deflection yoke as close to the purity magnet as possible.
7. Loosen the purity magnet clamp (See figure 7) and adjust the purity magnet to set the vertical green raster precisely at the center of the screen. (See figure 8.) Then tighten the clamp.
8. Slowly move the deflection yoke forward and adjust for the best overall green screen.
9. Tighten the deflection yoke clamp screw.
10. Produce a blue and red raster with the Cut-Off controls and observe that good purity is obtained on the respective field.
11. Observe that a uniform white raster is obtained by adjusting the R.G.B. Cut-Off controls. If the screen is not uniformly white, repeat the above procedure.

COLOR TEMPERATURE ADJUSTMENT

(See figure 9 and 10.)

1. Use a black and white video pattern.
2. Turn the R, G, and B Cut-Off controls fully counterclockwise, and then turn each forward (clockwise) 90°.
3. Turn the Screen Control (R550) fully counterclockwise and set Service Switch to the Service position.
4. Turn the Screen Control clockwise slowly, until any one of the R, G, or B lines just becomes visible. (See figure 9.)

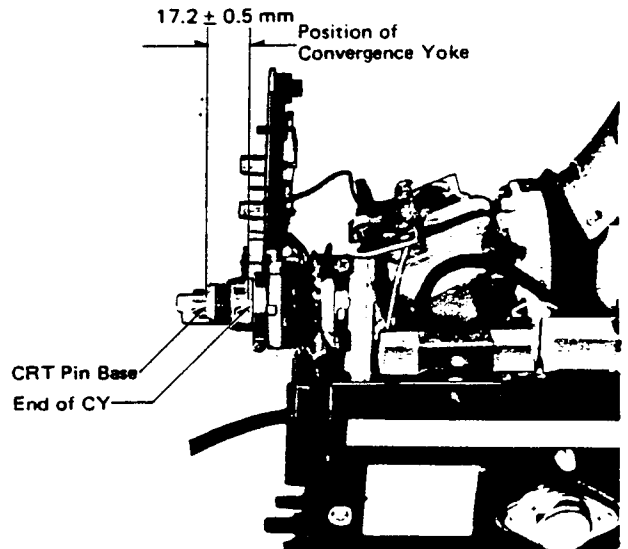

Figure 6

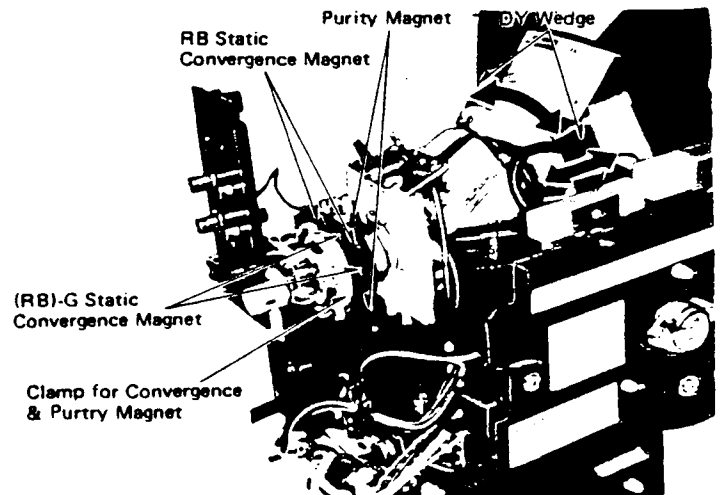
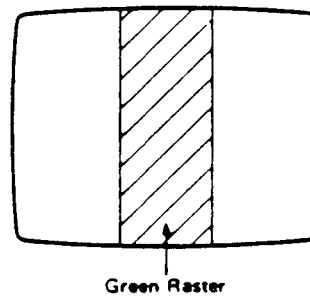
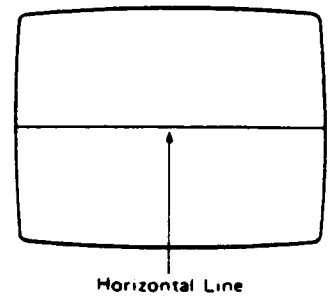

Figure 7



Green Raster

Figure 8



Horizontal Line

Figure 9

5. Turn the other two Cut-Off controls (for the colors which did not appear on the screen) slowly clockwise, so they also become just visible. (Adjust one control and color line at a time.)
6. Set the Service Switch in the Normal position.
7. Turn the Bright and Panabrite controls to maximum.
8. Adjust the drive controls to obtain a white raster at maximum brightness.

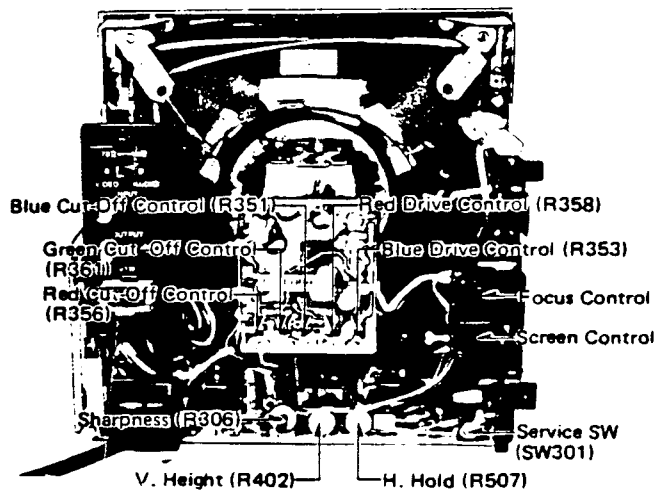

Figure 10

CONVERGENCE ADJUSTMENT

Note: Before any convergence adjustments are made vertical height and focus adjustment must be completed.

1. Use a dot pattern to complete this adjustment.
2. The brightness level should be no higher than necessary to obtain a clear pattern.
3. Loosen the convergence magnet clamp and converge the red and blue dots at the center of the screen, by rotating the R-B Static Convergence Magnet. (See figure 7.)
4. Align the converged red/blue dots with the green dots at the center of the screen, by rotating the (RB)-G Static Convergence Magnet. (See figure 7.)
5. Tighten the convergence magnet clamp.
6. Remove the DY wedges (see figure 7) and slightly tilt (do not rotate) the deflection yoke horizontally and vertically to obtain good overall convergence.
7. Secure the deflection yoke by reinserting the wedges. (See figure 11.)
8. If purity error is found, repeat the purity adjustments.

NOTE:

1. Wedge A shown in figure 11 should be fixed within a range of $0^\circ \sim 30^\circ$ to the left of the vertical line as shown.
2. After inserting wedge A, insert wedges B and C. The wedges should be set 120° apart from each other.
3. Be certain that the three wedges are firmly fixed and the Deflection Yoke is tightly clamped in place. Otherwise the Deflection Yoke may shift its position and cause a loss of convergence and purity.

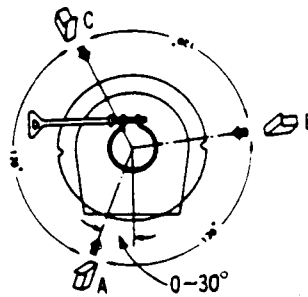

Figure 11

B. WITH TEST EQUIPMENT

When measuring voltage with a VTVM, be sure to use the test points located at the conductor side of the circuit boards. Use an isolation transformer for these.

POWER LINE VOLTAGE (116V) ADJUSTMENT

1. Connect a voltmeter between TP91 and ground.
2. Adjust R809 to obtain a reading of $116.0 \text{ V} \pm 0.5 \text{ V}$.

HIGH VOLTAGE ADJUSTMENT

1. Adjust color temperature. (See color temperature adjustment.)
2. Slide the Service Switch to the Service position.
3. Use an electrostatic type high voltage meter to confirm that the high voltage is within the range of $24.0 \text{ kV} \pm 1.0 \text{ kV}$.
4. If the high voltage is out of tolerance, adjust R809 until the high voltage is within tolerance without over or under going B+ voltage tolerance.

Note: Be certain that B+ is $116.0 \text{ V} \pm 0.5 \text{ V}$ with beam current at zero during the High Voltage Adjustment.

ABL ALIGNMENT

This is factory aligned. Usually no further alignment is required in the field. However, when the A-Board, or CRT is replaced, the following alignment is necessary.

1. Set the monitor to receive a cross hatch pattern from a video signal generator.
2. Set Bright and Panabrite controls at each click position.
3. Connect the DC voltmeter between TP86 and TP87 (positive lead of the voltmeter to TP87 and negative lead to TP86.)
4. Adjust the ABL control (R313) to obtain a voltmeter reading of $6.0 \text{ V} \pm 0.2 \text{ V}$.

GENERAL ALIGNMENT

Note: Use Video Pattern Generator for following alignments. (Video input should read 1.0 Vp-p.)

ALIGNMENT OF SUB CONTRAST

1. Use a color bar signal.
2. Set Color control (R605) fully counterclockwise.
3. Connect an oscilloscope to TP48 of C-Board. (TNP12950ZA)
4. Adjust the SUB-CONT control (R303) to obtain 1.7 V p-p \pm 0.1 V p-p from the white level to pedestal level. (See figure 12.)

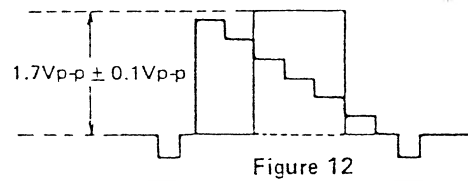

APC ALIGNMENT

Preliminary Steps (See figure 13)

1. Use a color bar signal.
2. Set Color Control (R605), Bright Control (R309) and Panabrite Control (R304) in a fully clockwise position.
3. Set Tint Control (R603) to mid-position.
4. Connect a jumper between terminal ⑩ and terminal ⑪ of IC601.
5. Connect a 15 k Ω resistor between terminal ⑫ of IC601 and +12 V Line.

Alignment Procedure

1. Adjust APC Control (C607) to just sync the color bars.
2. Remove the jumper between terminal ⑩ and terminal ⑪ of IC601.
3. Remove the 15 k Ω resistor between terminal ⑫ of IC601 and +12 V Line.

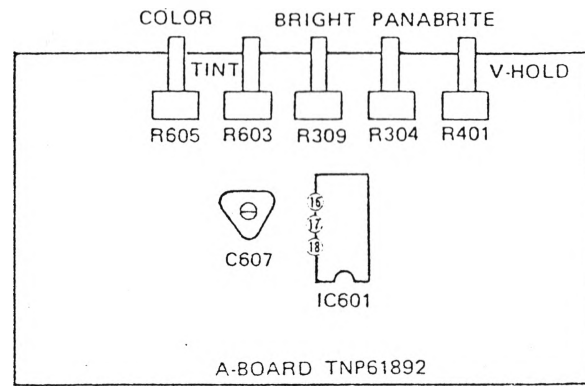

Figure 13

HORIZONTAL HOLD ALIGNMENT

Alignment Procedure

1. Use a black and white video pattern.
2. Turn Horizontal-Hold Control VR (R507) on main circuit board fully counterclockwise.
3. Short R529 with jumper wire.
4. Turn the VR (R507) slowly clockwise and set at the point where horizontal hold just pulls-in.
5. Disconnect jumper wire.

CIRCUIT EXPLANATION

HORIZONTAL OSC. DISABLE CIRCUIT

1. Under normal operating conditions, zener diode (D505) is cut OFF due to its low cathode voltage.
2. When the pulse amplitude applied to diode D504 increases, it raises the cathode voltage of zener diode D505.

As a result, D505 conducts.

3. The conduction of D505 increases pin ⑤ voltage of IC401. This causes the Horizontal Oscillator Circuit to stop and the high voltage is reduced to zero.

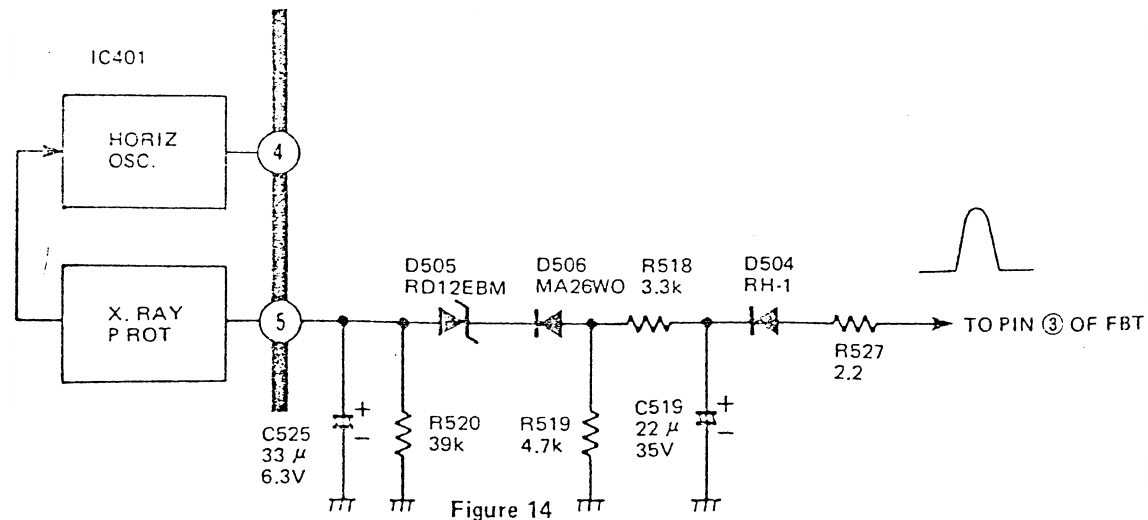
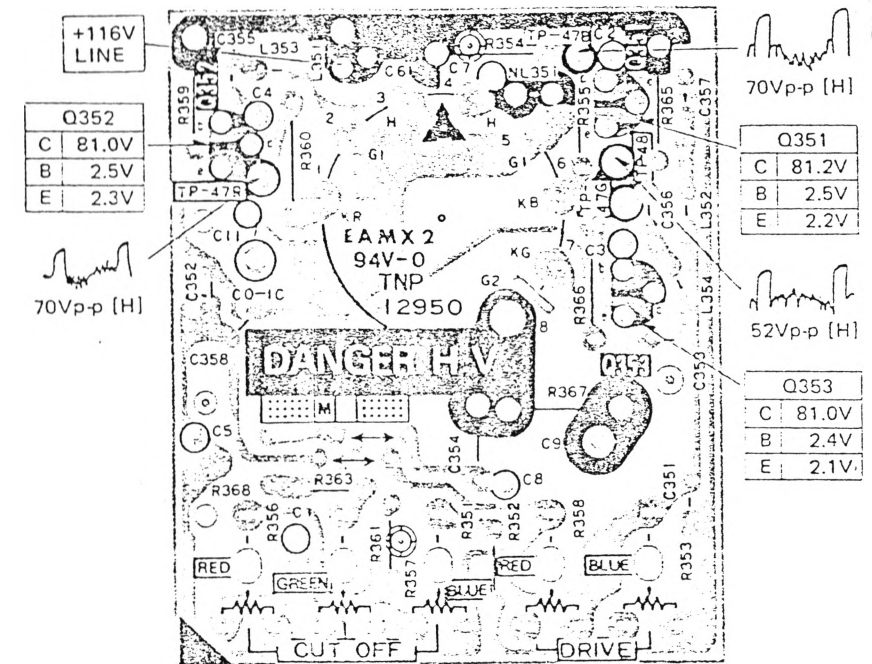

Figure 14

CONDUCTOR VIEWS

C-BOARD TNP12950ZA



D-BOARD TNP55997ZA

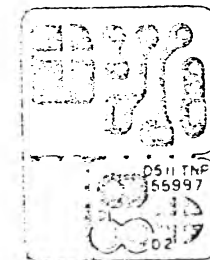

A-BOARD TNP61892BC FOR CT-110MA
TNP61892CD FOR CT-110MCA

IC501			
1	12V	15	9.5V
2	9V	16	8.7V
3	9V	17	8.3V
4	6.3V	18	10.7V
5	3.3V	19	4.4V
6	2.6V	20	0V
7	3V	21	8.7V
8	6V	22	3.4V
9	3.3V	23	3.4V
10	12.5V	24	0.9V
11	9.2V	25	3V
12	1.9V	25	2.4V
13	1.3V	27	2.3V
14	0V	25	2.4V

IC501			
1	5.2V	10	6.5V
2	2.2V	11	6.7V
3	2.1V	12	2.1V
4	5.4V	13	5.5V
5	0V	14	5.5V
6	2V	15	13.5V
7	9.1V	16	10.9V
8	0V	17	2.9V
9	0.6V	18	0.15V

C503		
C	15.5V	
B	13.2V	
E	12.0V	

C204		
C	115V	
B	43V	
E	42V	

Q203		
C	42V	
B	0.5V	
E	0V	

C202		
C	8.4V	
B	1.2V	
E	0.5V	

Q201		
C	5.6V	
B	4V	
E	3.4V	

Q304		
C	12V	
B	6.2V	
E	5.3V	

Q302		
C	9.4V	
B	6.1V	
E	5.3V	

Q001		
C	5.6V	
B	4V	
E	4V	

Q002		
C	5.6V	
B	4V	
E	3.3V	

Q301		
C	12V	
B	5.9V	
E	5.2V	

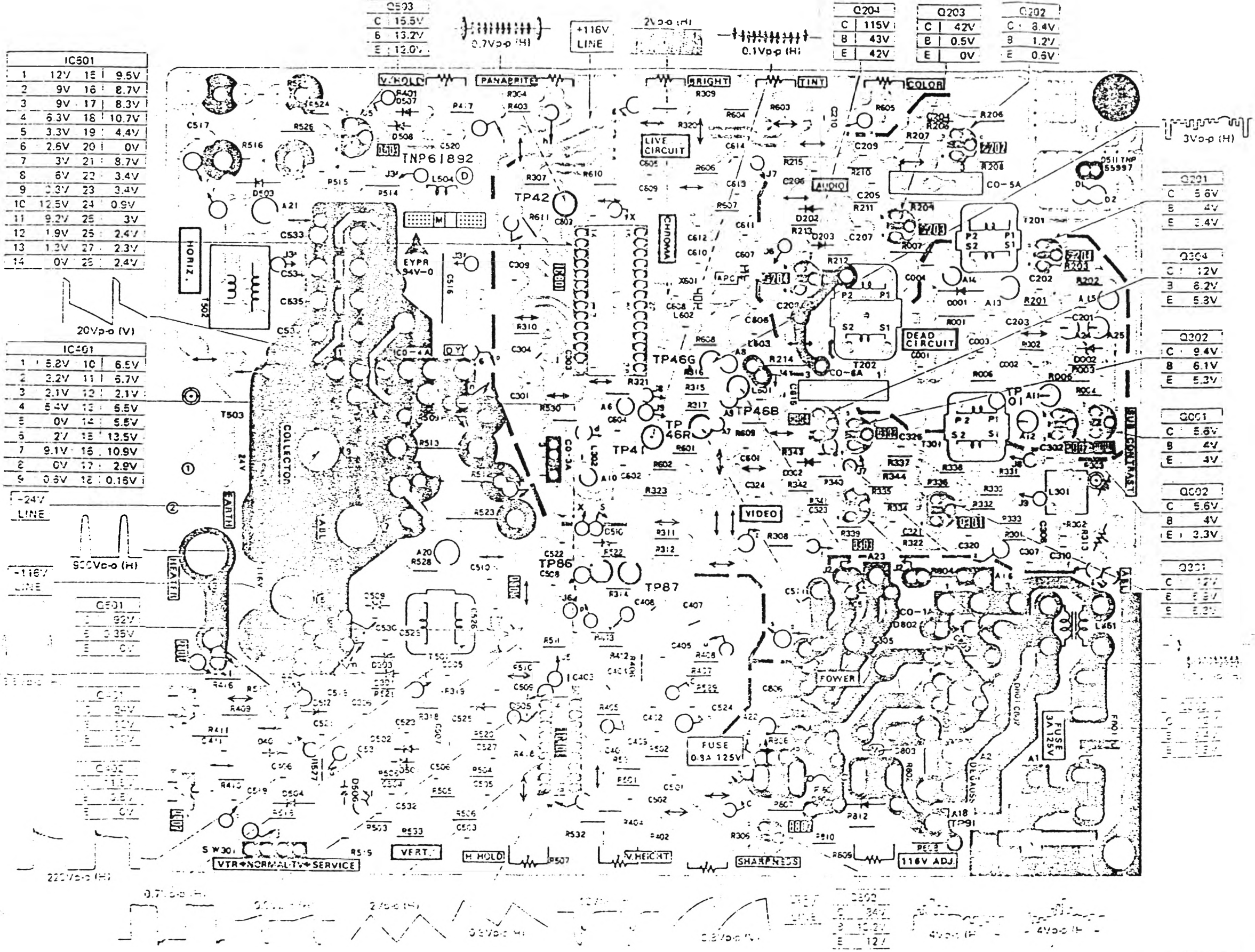

SCHEMATIC DIAGRAM FOR MODELS CT-110MA (CHASSIS NO. NMX-K6NA) CT-110MCA (CHASSIS NO. NMX-K6NB)

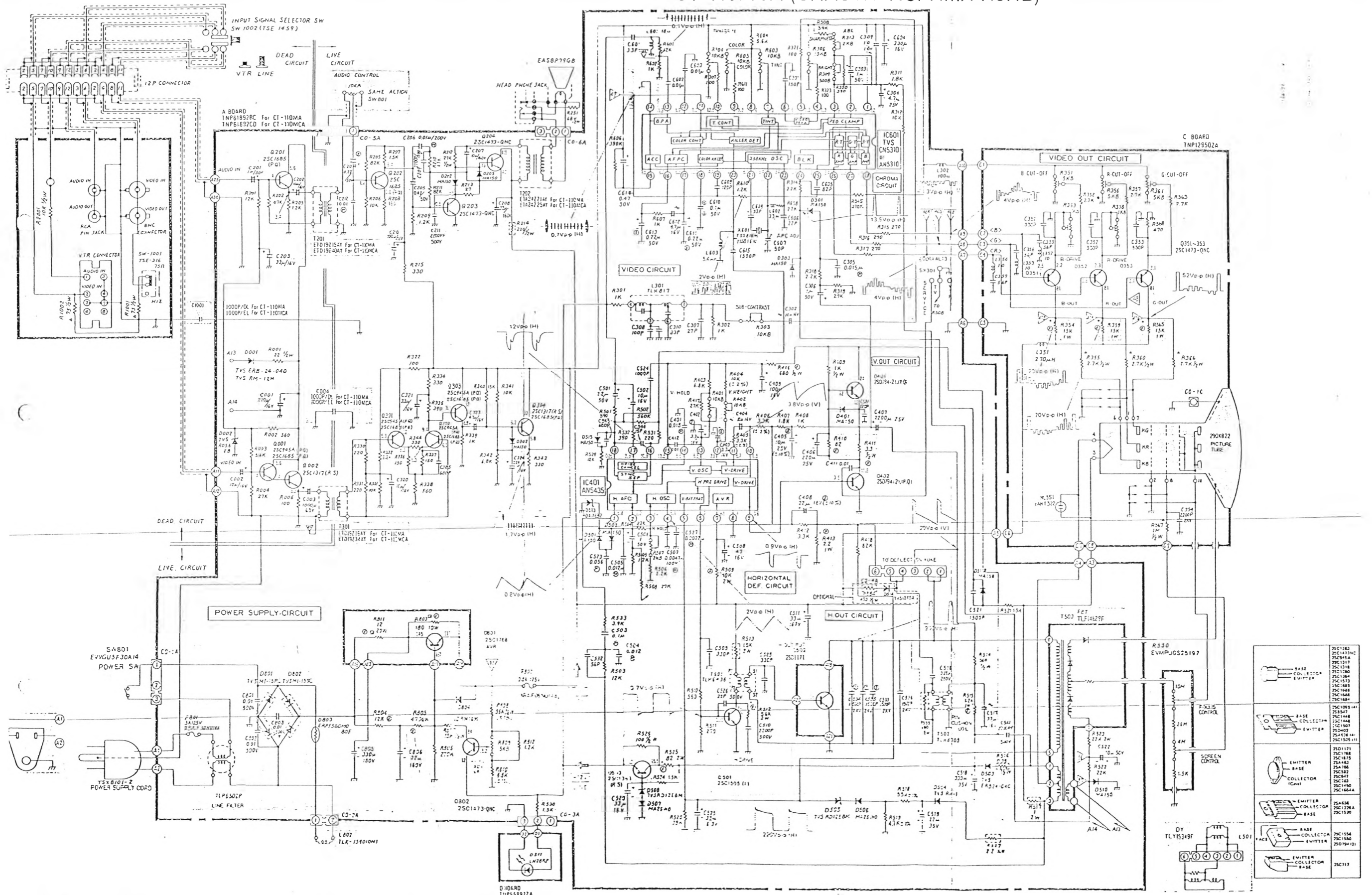

IMPORTANT SAFETY NOTICE

THE SHADED AREA ON THIS SCHEMATIC DIAGRAM INCORPORATES SPECIAL FEATURES IMPORTANT FOR PROTECTION FROM X-RADIATION, FIRE AND ELECTRICAL SHOCK HAZARDS. WHEN SERVICING IT IS ESSENTIAL THAT ONLY MANUFACTURER'S SPECIFIED PARTS BE USED FOR THE CRITICAL COMPONENTS IN THE SHADED AREAS OF THE SCHEMATIC.

NOTICE

1. RESISTOR
All resistors are carbon 1/4W resistor, unless otherwise noted in the following marks.
Unit of resistance is OHM (Ω), K = 1,000, M = 1,000,000.
△ Solid resistor
○ Metal oxide resistor
□ Wire wound resistor
⊞ Non-inflammable resistor

2. CAPACITOR
All capacitors are ceramic 50V capacitor, unless otherwise noted in the following marks. Unit of capacitance is μF, unless otherwise noted.
X Polyester capacitor
3 Polystyrene capacitor
-E Electrolytic capacitor
□ Cement

3. TEST POINT
▽ Test point position.

4. VOLTAGE MEASUREMENT
Voltage is measured by a VOM (receiving color bar signal, when all controls are set to the maximum position).

5. CONNECTION
When shown the (1) is found, connection is easily found along with the direction of an arrow.

6. THIS SCHEMATIC IS THE LATEST AS OF THE DATE OF PRINTING.

	25C1343
	25C1413NC
	25C1511
	25C1512
	25C1513
	25C1514
	25C1515
	25C1516
	25C1517
	25C1518
	25C1519
	25C1520
	25C1521
	25C1522
	25C1523
	25C1524
	25C1525
	25C1526
	25C1527
	25C1528
	25C1529
	25C1530
	25C1531
	25C1532
	25C1533
	25C1534
	25C1535
	25C1536
	25C1537
	25C1538
	25C1539
	25C1540
	25C1541
	25C1542
	25C1543
	25C1544
	25C1545
	25C1546
	25C1547
	25C1548
	25C1549
	25C1550
	25C1551
	25C1552
	25C1553
	25C1554
	25C1555
	25C1556
	25C1557
	25C1558
	25C1559
	25C1560
	25C1561
	25C1562
	25C1563
	25C1564
	25C1565
	25C1566
	25C1567
	25C1568
	25C1569
	25C1570
	25C1571
	25C1572
	25C1573
	25C1574
	25C1575
	25C1576
	25C1577
	25C1578
	25C1579
	25C1580
	25C1581
	25C1582
	25C1583
	25C1584
	25C1585
	25C1586
	25C1587
	25C1588
	25C1589
	25C1590
	25C1591
	25C1592
	25C1593
	25C1594
	25C1595
	25C1596
	25C1597
	25C1598
	25C1599
	25C1600

EXPLODED VIEWS

CABINET PARTS

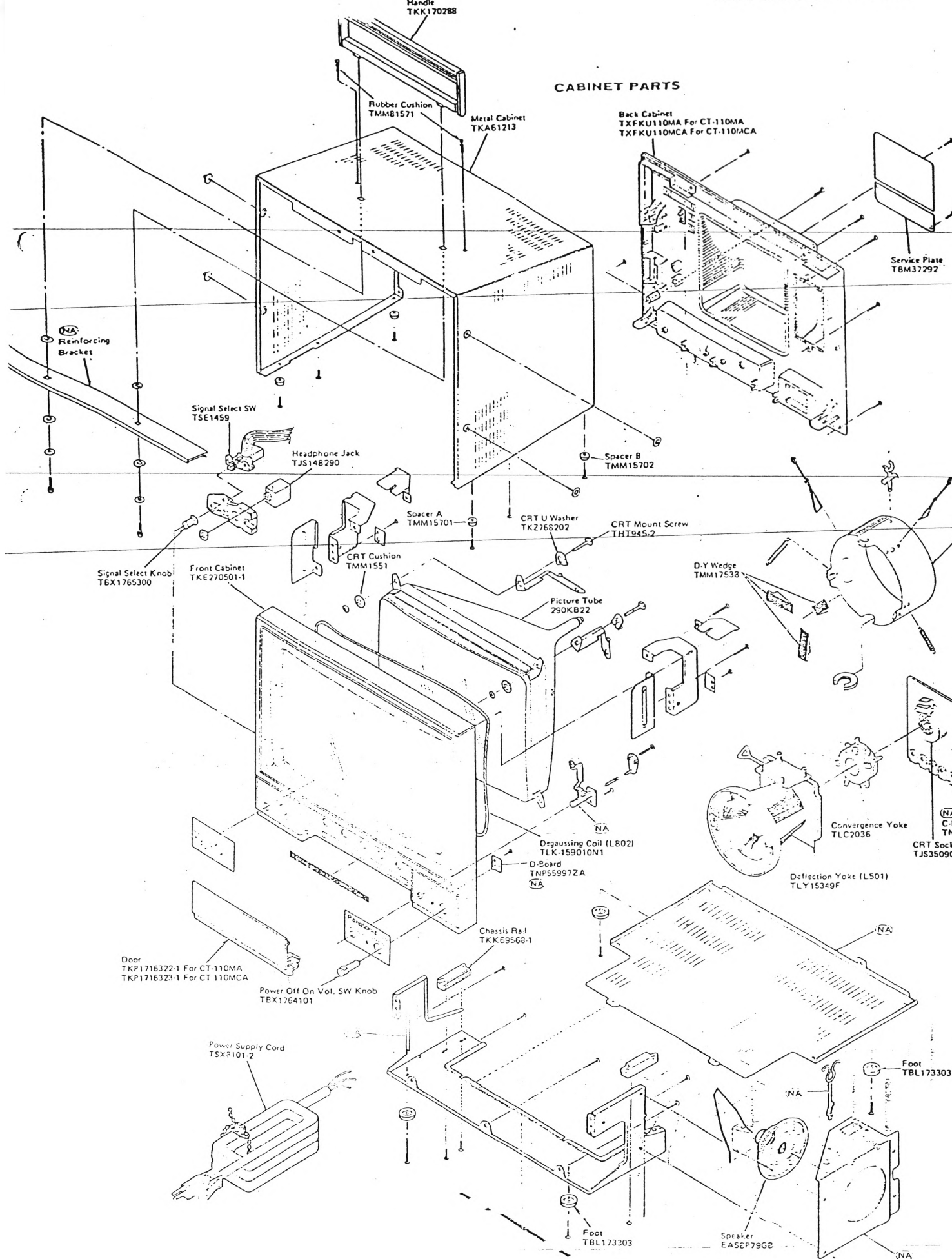

CHASSIS PARTS

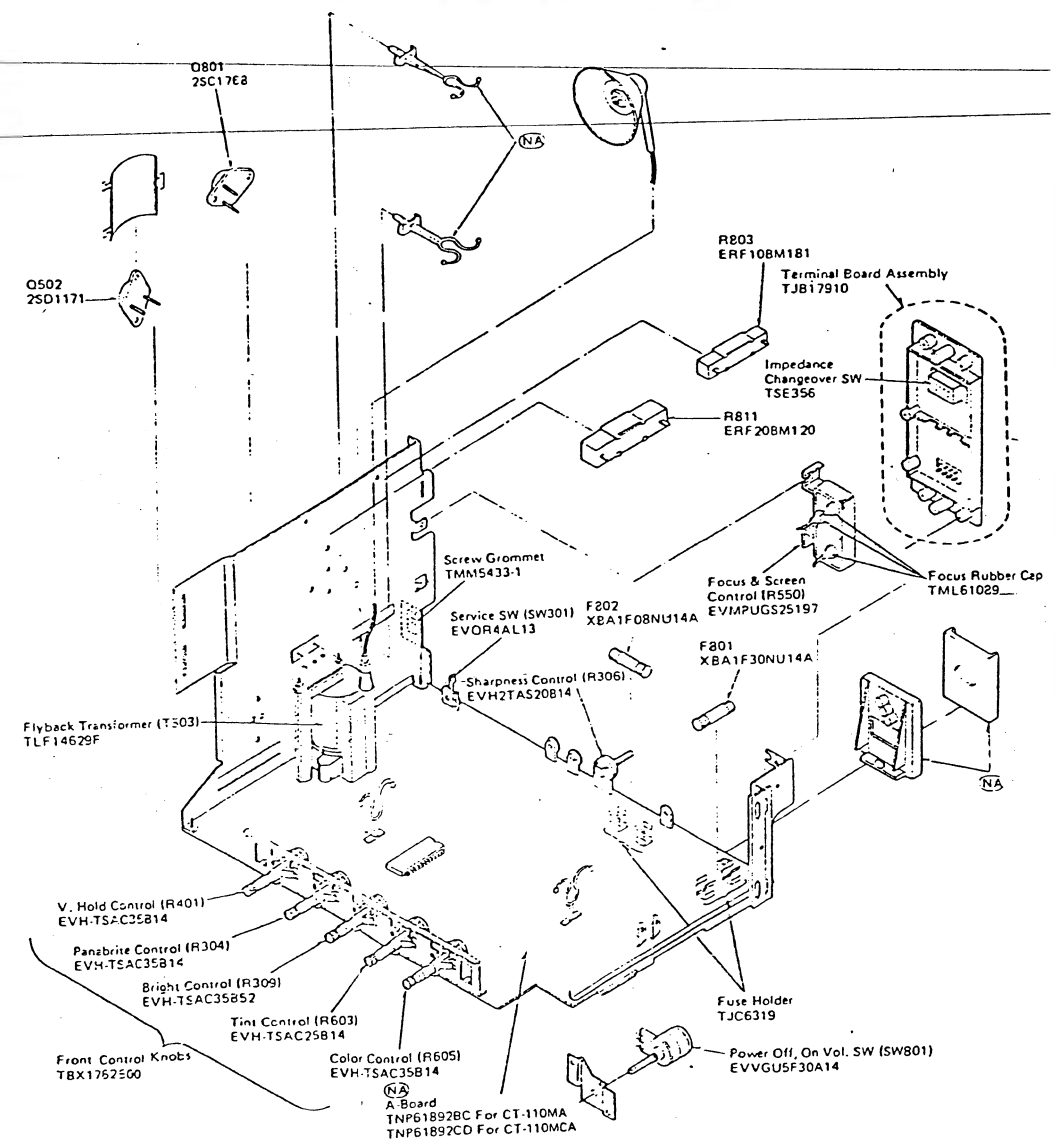

NOTE: Parts or Components marked with (NA) and unlisted are not available as replacement parts.

REPLACEMENT PARTS LIST

Important Safety Notice

Components identified by shaded area have special characteristics important for safety. When replacing any of these

components use only manufacturer's specified parts.

Note: TNP61892BC (A-Board), TNP61892CD (A-Board), TNP12950ZA (C-Board) and TNP55997ZA (D-Board) are not available as a complete printed circuit board.

Ref. No.	Part No.	Description	Ref. No.	Part No.	Description
	RESISTORS				
R001	ERD50TJ220	C 22ohm J 1/2W	R332	ERD25TJ682	C 6.8Kohm J 1/4W
R002	ERD25TJ561	C 560ohm J 1/4W	R333	ERD25TJ103	C 10Kohm J 1/4W
R003	ERD25TJ562	C 5.6Kohm J 1/4W	R334	ERD25TJ331	C 330ohm J 1/4W
R004	ERD25TJ273	C 27Kohm J 1/4W	R335	ERD25TJ391	C 390ohm J 1/4W
R006	ERD25TJ101	C 100ohm J 1/4W	R336	ERD25TJ151	C 150ohm J 1/4W
R201	ERD25TJ123	C 12Kohm J 1/4W	R337	ERD25TJ151	C 150ohm J 1/4W
R202	ERD25TJ473	C 47Kohm J 1/4W	R338	ERD25TJ561	C 560ohm J 1/4W
R203	ERD25TJ122	C 1.2Kohm J 1/4W	R339	ERD25TJ102	C 1Kohm J 1/4W
R205	ERD25TJ823	C 82Kohm J 1/4W	R340	ERD25TJ153	C 15Kohm J 1/4W
R206	ERD25TJ103	C 10Kohm J 1/4W	R341	ERD25TJ103	C 10Kohm J 1/4W
R207	ERD25TJ152	C 1.5Kohm J 1/4W	R342	ERD25TJ682	C 6.8Kohm J 1/4W
R208	ERD25TJ151	C 150ohm J 1/4W	R343	ERD25TJ331	C 330ohm J 1/4W
R209	ERD25TJ122	C 1.2Kohm J 1/4W	R344	ERD25TJ331	C 330ohm J 1/4W
R210	ERD25TJ473	C 47Kohm J 1/4W	R345	ERD25TJ474	C 470Kohm J 1/4W
R211	ERD25TJ823	C 82Kohm J 1/4W	R351	EVLS3MA00B53	CONTROL B 5Kohm
R212	ERD50TJ273	C 27Kohm J 1/2W	R352	ERD25TJ272	C 2.7Kohm J 1/4W
R213	ERD25TJ270	C 27ohm J 1/4W	R353	EVLS3MA00B13	CONTROL B 1Kohm
R214	ERQ12HJ221	F 220ohm J 1/2W	R354	ERG1ANJ153H	M 15Kohm J 1W
R215	ERD25TJ331	C 330ohm J 1/4W	R355	ERC12GM272	S 2.7Kohm M 1/2W
R251	ERD50TJ680	C 68ohm J 1/2W	R356	EVLS3MA00B53	CONTROL B 5Kohm
R301	ERD25TJ102	C 1Kohm J 1/4W	R357	ERD25TJ272	C 2.7Kohm J 1/4W
R302	ERD25TJ102	C 1Kohm J 1/4W	R358	EVLS3MA00B13	CONTROL B 1Kohm
R303	EVLS0MA00B14	CONTROL B 10Kohm	R359	ERG1ANJ153H	M 15Kohm J 1W
R304	EVHTLAF25B14	CONTROL B 10Kohm	R360	ERC12GM272	S 2.7Kohm M 1/2W
R306	EVH2TAS20B14	CONTROL B 10Kohm	R361	EVLS3MA00B53	CONTROL B 5Kohm
R307	ERD25TJ101	C 100ohm J 1/4W	R363	ERD25TJ272	C 2.7Kohm J 1/4W
R308	ERD25TJ392	C 3.9Kohm J 1/4W	R365	ERG1ANJ153H	M 15Kohm J 1W
R309	EVHTLAF25B52	CONTROL B 500ohm	R366	ERC12GM272	S 2.7Kohm M 1/2W
R311	ERD25TJ182	C 1.8Kohm J 1/4W	R367	ERC12GM105	S 1Mohm M 1/2W
R312	ERD25TJ103	C 10Kohm J 1/4W	R368	ERD25TJ471	C 470ohm J 1/4W
R313	EVLS0MA00B23	CONTROL B 2Kohm	R401	EVHTAAF25B14	CONTROL B 10Kohm
R314	ERD25TJ222	C 2.2Kohm J 1/4W	R402	EVLV0N00MB14	CONTROL B 10Kohm
R315	ERD25TJ271	C 270ohm J 1/4W	R403	ERD25TJ682	C 6.8Kohm J 1/4W
R316	ERD25TJ271	C 270ohm J 1/4W	R404	ERD25CKF1002	C 10Kohm F 1/4W
R317	ERD25TJ271	C 270ohm J 1/4W	R405	ERD25CKF3301	C 3.3Kohm F 1/4W
R318	ERD25TJ222	C 2.2Kohm J 1/4W	R406	ERD25CKF3301	C 3.3Kohm F 1/4W
R319	ERD25TJ272	C 2.7Kohm J 1/4W	R407	ERD25TJ182	C 1.8Kohm J 1/4W
R320	ERD25TJ391	C 390ohm J 1/4W	R408	ERD25TJ102	C 1Kohm J 1/4W
R321	ERD25TJ101	C 100ohm J 1/4W	R409	ERD50TJ102	C 1Kohm J 1/2W
R322	ERD25TJ101	C 100ohm J 1/4W	R410	ERD25FJ820	C 82ohm J 1/4W
R323	ERD25TJ101	C 100ohm J 1/4W	R411	ERQ12AJ3R3P	F 3.3ohm J 1/2W
R330	ERD25TJ221	C 220ohm J 1/4W	R412	ERD25TJ332	C 3.3Kohm J 1/4W
R331	ERD25TJ221	C 220ohm J 1/4W	R413	ERX1ANJ2R2H	M 2.2ohm J 1W
			R416	ERD50TJ681	C 680ohm J 1/2W
			R417	ERD25TJ273	C 27Kohm J 1/4W

Ref. No.	Part No.	Description	Ref. No.	Part No.	Description
R418	ERD25TJ823	C 82Kohm J 1/4W	R611	ERD25TJ101	C 100ohm J 1/4W
R419	ERD25TJ100	C 10ohm J 1/4W	R803	ERF10HMJ271	W 270ohm J 10W
R501	ERD25TJ391	C 390ohm J 1/4W	R804	ERD25FJ123	C 12Kohm J 1/4W
R502	ERD25TJ564	C 560Kohm J 1/4W	R805	ERQ14AJ470P	F 47ohm J 1/4W
R503	ERD25TJ123	C 12Kohm J 1/4W	R806	ERD25TJ274	C 270Kohm J 1/4W
R504	ERD25TJ223	C 22Kohm J 1/4W	R807	ERD50TJ153	C 15Kohm J 1/2W
R505	ERD25TJ123	C 12Kohm J 1/4W	R808	ER050CKF5602	M 56Kohm F 1/2W
R506	ERD25TJ222	C 2.2Kohm J 1/4W	R809	EVLS0MA00B53	CONTROL B 5Kohm
R507	EVLV0N00MB23	CONTROL B 2Kohm	R810	ER025CKF6801	M 6.8Kohm F 1/4W
R508	ERD25TJ273	C 27Kohm J 1/4W	R811	ERF20HMJ120Y	W 12ohm J 20W
R509	ERG2ANJ103H	M 10Kohm J 2W	R812	ERD25TJ122	C 1.2Kohm J 1/4W
R510	ERD25TJ561	C 560ohm J 1/4W	R1001	ERC126J750	S 75ohm J 1/2W
R511	ERD25TJ271	C 270ohm J 1/4W	R1002	ERC126J750	S 75ohm J 1/2W
R512	ERG2ANJ562H	M 5.6Kohm J 2W	R2001	ERD50TJ103	C 10Kohm J 1/2W
R513	ERG2ANJ152	M 1.5Kohm J 2W	CAPACITORS		
R514	ERD50TJ561	C 560ohm J 1/2W	C001	ECEA1CS221	E 220uF 16V
R515	ERG1ANJ122H	M 1.2Kohm J 1W	C002	ECEA1CS100	E 10uF 16V
R516	ERQ12HKR39	F 0.39ohm K 1/2W	C003	ECEA0JS102	E 1000uF 6.3V
R517	ERQ2CJ1R0	F 1ohm J 2W	C004	ECKDDL102ZE	Type DL/CT-110MA
R518	ER025CKF3301	M 3.3Kohm F 1/4W	C004	ECKDEL102MD	Type EL/CT-110MCA
R519	ER025CKF4701	M 4.7Kohm F 1/4W	C201	ECEA1HS010	E 1uF 50V
R520	ERD25TJ393	C 39Kohm J 1/4W	C202	ECEA1CS100	E 10uF 16V
R521	ERD25TJ152	C 1.5Kohm J 1/4W	C203	ECEA1CS330	E 33uF 16V
R522	ERD25TJ223	C 22Kohm J 1/4W	C204	ECEA50ZR22	E 0.22uF 50V
R523	ERG2ANJ223	M 22Kohm J 2W	C205	ECEA1HSR47	E 0.47uF 50V
R524	ERD25TJ152	C 1.5Kohm J 1/4W	C206	ECQM2103KZ	F 0.01uF K 200V
R525	ERG2ANJ820H	M 82ohm J 2W	C207	ECEA2CS100	E 10uF 160V
R526	ERD50TJ101	C 100ohm J 1/2W	C208	ECEA2CS220	E 22uF 160V
R527	ERQ14AJ2R2P	F 2.2ohm J 1/4W	C209	ECKD2H272KB2	C 2700pF K 500V
R529	ERD25TJ123	C 12Kohm J 1/4W	C210	ECEA1CS101	E 100uF 16V
R530	ERD25TJ152	C 1.5Kohm J 1/4W	C211	ECKD2H222KB2	C 2200pF K 500V
R531	ERD25TJ221	C 220ohm J 1/4W	C212	ECQM1H103KZ	F 0.01uF K 50V
R532	ERD25TJ391	C 390ohm J 1/4W	C301	ECKF1H151KB	C 150pF K 50V
R533	ERD25TJ392	C 3.9Kohm J 1/4W	C302	ECEA1CN100S	E 10uF 16V
R534	ERQ12AJ471	F 470ohm J 1/2W	C303	ECEA1HN010S	E 1uF 50V
R550	EVMPUGS25197	CONTROL	C304	ECEA1ES4R7	E 4.7uF 25V
R601	ERD25TJ122	C 1.2Kohm J 1/4W	C305	ECQM1H153KZ	F 0.015uF K 50V
R602	ERD25TJ102	C 1Kohm J 1/4W	C306	ECEA1HS010	E 1uF 50V
R603	EVHTAAF25B14	CONTROL B 10Kohm	C307	ECCF1H270J	C 27pF J 50V
R604	ERD25TJ562	C 5.6Kohm J 1/4W	C308	ECKF1H101KB	C 100pF K 50V
R605	EVHTAAF25B14	CONTROL B 10Kohm	C309	ECEA1CS100	E 10uF 16V
R606	ERD25TJ394	C 390Kohm J 1/4W	C310	ECCF1H330JC	C 33pF J 50V
R607	ERD25TJ102	C 1Kohm J 1/4W	C320	ECEA1CS100	E 10uF 16V
R608	ERD25TJ222	C 2.2kohm J 1/4W	C321	ECEA1CS330	E 33uF 16V
R610	ERD25TJ122	C 1.2Kohm J 1/4W			

Ref. No.	Part No.	Description	Ref. No.	Part No.	Description
C323	ECSZ16EF4R7E	T 4.7uF 16V	C531	ECKF1H121KB	C 120pF K 50V
C324	ECEA1CS221	E 220uF 16V	C532	ECCF1H560J	C 56pF J 50V
C325	ECKF1H681KB	C 680pF K 50V	C533	ECKD3D152JB8	C 1500pF J 2KV
C351	ECKF1H331KB	C 330pF K 50V	C534	ECKD3D152JB8	C 1500pF J 2KV
C352	ECKF1H331KB	C 330pF K 50V	C535	ECKD3D152JB8	C 1500pF J 2KV
C353	ECKF1H331KB	C 330pF K 50V	C536	ECKD3D152JB8	C 1500pF J 2KV
C354	ECKD3D222KBN	C 2200pF K 2KV	C541	ECKD2H222KB2	C 2200pF K 500V
C355	ECCF1H560J	C 56pF J 50V	C543	ECKF1H681KB	C 680pF K 50V
C356	ECCF1H560J	C 56pF J 50V	C544	ECCF1H150JC	C 15pF J 50V
C357	ECCF1H560J	C 56pF J 50V	C601	ECCF1H330J	C 33pF J 50V
C401	ECQM1H183KZ	P 0.018uF K 50V	C602	ECKF1H103ZF	C 0.01uF Z 50V
C402	ECSZ16EF3R3V	T 3.3uF 16V	C603	ECQM1H103KZ	P 0.01uF K 50V
C403	ECSZ16HS3R3	T 3.3uF 16V	C604	ECEA1CS331	E 330uF 16V
C404	ECEA1CN101S	E 100uF 16V	C605	ECCF1H820J	C 82pF J 50V
C405	ECEA25Z10	E 10uF 25V	C606	ECCF1H220J	C 22pF J 50V
C406	ECEA1ES221	E 220uF 25V	C607	ECV1ZW50X32	Trimmer
C407	ECEA1ES222	E 2200uF 25V	C608	ECCF1H330JC	C 33pF J 50V
C408	ECEA16Z22	E 22uF 16V	C609	ECKF1H121KB	C 120pF K 50V
C409	ECEA1CS101	E 100uF 16V	C610	ECQM1H823KZ	P 0.082uF K 50V
C411	ECKF1H103ZF	C 0.01uF Z 50V	C611	ECEA50ZR22	E 0.22uF 50V
C412	ECKF1H103ZF	C 0.01uF Z 50V	C612	ECEA1EN4R7S	E 4.7uF 25V
C501	ECEA1HS2R2	E 2.2uF 50V	C613	ECEA50ZR22	E 0.22uF 50V
C502	ECEA1CS100	E 10uF 16V	C614	ECEA1HSR47	E 0.47uF 50V
C503	ECQM1H104MZ	P 0.1uF M 50V	C615	ECKF1H152KB	C 1500pF K 50V
C504	ECQM1H123KZ	P 0.012uF K 50V	C801	ECKD2H103PE7	C 0.01uF P 500V
C505	ECQM1H123KZ	P 0.012uF K 50V	C802	ECKD2H103PE7	C 0.01uF P 500V
C506	ECEA1HS010	E 1uF 50V	C803	ECKD2H103PE7	C 0.01uF P 500V
C507	ECQP1472JZ	P 4700pF J 100V	C805	ECET2PR331SW	E 330uF 180V
C508	ECEA1CS470	E 47uF 16V	C806	ECEA2CS220	E 22uF 160V
C509	ECKF1H331KB	C 330pF K 50V	C1001	ECKDDL102ZE	Type DL/CT-110MA
C510	ECKD2H222KB2	C 2200pF K 500V	C1001	ECKDEL102MD	Type EL/CT-110MCA
C511	ECEA160V33Z	E 33uF 160V	COILS		
C516	ECQF2H274JZ	P 0.27uF J 200V	L301	TLK817	Delay Line
C517	ECEA1CN330S	E 33uF 16V	L302	TLT101K999G	Peaking 100uH
C518	ECEA1VS331	E 330uF 35V	L351	TLT271K999G	Peaking 270uH
C519	ECEA1VS220	E 22uF 35V	L352	TLQ100K205C	Peaking 10uH
C520	ECEA1CS330	E 33uF 16V	L353	TLQ100K205C	Peaking 10uH
C521	ECKF1H152KB	C 1500pF K 50V	L354	TLQ100K205C	Peaking 10uH
C522	ECEA1HS100	E 10uF 50V	L501	TLY15349F	Deflection Yoke
C523	ECQM1H563MZ	P 0.056uF M 50V	L601	TLQ180K205C	Peaking 18uH
C524	ECKF1H102KB	C 1000pF K 50V	L602	TLQ330K205C	Peaking 33uH
C525	ECEA0JS330	E 33uF 6.3V	L603	TLT542K999G	Peaking 5.4mH
C526	ECDD2H220K	C 22pF K 500V	L802	TLK159010N1	Degauss Coil
C527	ECQM1H222JZ	P 2200pF J 50V			
C528	ECKF1H331KB	C 330pF K 50V			

Ref. No.	Part No.	Description	Ref. No.	Part No.	Description
E851	TLP6502P	Line Filter	Q201	2SC1685-P.Q	Audio Amp
	TRANSFORMERS		Q202	2SC1685-P.Q	Audio Amp
T201	ETD19Z15AY	Audio/CT-110MA	Q203	2SC1473-QNC	Audio Out
T201	ETD19Z40AY	Audio/CT-110MCA	Q204	2SC1473-QNC	Audio Out
T202	ETA24Z21AY	Audio/CT-110MA	Q301	2SC945A-P.Q	Video Amp
T202	ETA24Z25AY	Audio/CT-110MCA	Q302	2SC945A-P.Q	Video Amp
T301	ETD19Z16AY	Video/CT-110MA	Q303	2SC945A-P.Q	Video Amp
T301	ETD19Z34AY	Video/CT-110MCA	Q304	2SC1317-R.S	Video Amp
T501	TLH6436	H. Drive Trans.	Q351	2SC1473-QNC	Video Out (B)
T502	TLH8709	Pinc. Correction	Q352	2SC1473-QNC	Video Out (R)
T503	TLF14629F	Flyback Trans.	Q353	2SC1473-QNC	Video Out (G)
	DIODES		Q401	2SD794(2)	V. Out-P.Q
D001	TVSRM1ZM	Diode	Q402	2SD794(2)	V. Out-P.Q
D002	TVSRD5.6EB	Zener Diode 5.6V	Q501	2SC1505(1)	H. Drive
D202	MA150	Diode	Q502	2SD1171	H. Out
D203	MA150	Diode	Q503	2SC1383-R.S	Regulator
D301	MA150	Diode	Q801	2SC1768	Regulator
D302	MA150	Diode	Q802	2SC1473-QNC	Error Detector
D303	MA150	Diode		I.C.	
D401	MA150	Diode	IC401	AN5435	H/V Osc. V Drive
D501	MA150	Diode	IC601	TVSCN5310	Chroma
D502	MA150	Diode		FILTERS	
D503	TVSERB24-04C	Diode	X601	TSS816M	Crystal
D504	TVSRH1	Diode		SWITCHES	
D505	TVSRD12EBM	Zener Diode 12V	S301	EVQR4AL13	Service SW
D506	MA26WD	Diode	S801	EVVGU5F30A14	Switch Volume
D507	MA26WD	Diode	S1001	TSE356	Impede. Change SW
D508	TVSRD12EBM	Zener Diode 12V	S1002	TSE1459	Signal Select SW
D510	MA150	Diode		OTHERS	
D511	LN28RF	LED			
D512	MA150	Diode			
D513	TVSRD4.7EB2	Zener Diode 4.7V			
D514	TVS15954	Diode			
D515	MA150	Diode			
D801	TVSMI15RC	Diode		290KB22	Picture Tube
D802	TVSMI15SC	Diode		EAS8F79GB	Speaker
D803	ERPF5B0M080F	Posistor			
D804	TVSRM1ZM	Diode		TBL173303	Rubber Foot
	TRANSISTORS			TBM37292	Service Plate
Q001	2SC945A-P.Q	Video Amp		TBX1762500	Front Cont. Knobs
Q002	2SC1317-R.S	Video Amp		TBX1764101	Volume Cont. Knob
				TBX1765300	Signal Selec Knob

Ref. No.	Part No.	Description	Ref. No.	Part No.	Description
	THT945-2	CRT Mount Screw		TXFKU110MA	Back/CT-110MA
	TJB17910	Terminal Board		TXFKU110MCA	Back/CT-110MCA
	TJC6319	Fuse Holder		XANT322	Neon Lamp
	TJS148180	BNC Connector		XBA1F08NU14A	Fuse 125V 0.8A
	TJS148290	Headphone Jack		XBA1F30NU14A	Fuse 125V 3A
	TJS168110	3P Mini-Connector		XZB75X65C04	Set Cover
	TJS188010	RCA Socket			
	TJS29770	VTR 8P Connector			
	TJS5090	CRT Socket			
	TKA61213	Metal Cabinet			
	TKE270501-1	Front Cabinet			
	TKK170288	Handle			
	TKK69568-1	Chassis Rail			
	TKP1716322-1	Door/CT-110MA			
	TKP1716323-1	Door/CT-110MCA			
	TKZ768202	CRT U Washer			
	TLC2036	Convergence Yoke			
	TML61089	Focus Rubber Cap			
	TMM1551	CRT Cushion			
	TMM15701	Spacer A			
	TMM15702	Spacer B			
	TMM17538	DY Wedge			
	TMM5433-1	Screw Grommet			
	TMM81571	Rubber Cushion			
	TNP12950ZA	Circuit Board C			
	TNP55997ZA	Circuit Board D			
	TNP61892BC	A Board/CT-110MA			
	TNP61892CD	A Board/CT-110MCA			
	TPC62033	Carton/CT-110MA			
	TPC62034	Carton/CT-110MCA			
	TPD159619	Cushion Front			
	TPD191171	Cushion Top (R)			
	TPD191172	Cushion Top (L)			
	TPD192177	Cushion Bottom (R)			
	TPD192178	Cushion Bottom (L)			
	TQB611617	Fan Bag/CT-110MA			
	TQB611618	Fan Bag/CT-110MCA			
	TSX8101-2	Power Supply Cord			
	TXAJT01112V	3P Coupl Kit-C05A			
	TXAJT02110M	12P Socket Kit			
	TXAJT02F5	3P Coupl Kit-C01A			
	TXAJT03110M	12P Plug Kit			
	TXAJT03112V	3P Coupl Kit-C03A			
	TXAJT04110M	3P Coupl Kit-C06A			
	TXFJT01110V	1P Tip Kit-C01C			

Service Manual

Color Monitor
Color Display

Supplement

CT-110MA, CT-1010M, CT-1020M
PHA4100A, CT-160, DT-D1000G
BT-S700N, BT-S701N, BT-S702N
FT-H900T

Please use this supplement manual together with original service manual for each model mentioned below:

Substitution of Transistors

Following transistors used for each model may be substituted by new types.

Original	Substitute	Used in Models
2SC1383 $V_{CB0} = 30V$ $V_{CE0} = 25V$	2SC1384 $V_{CB0} = 60V$ $V_{CE0} = 50V$	CT-110MA, PHA4100A, CT-160, CT-1020M, BT-S700N
2SB641 $-V_{CB0} = 30V$ $-V_{CE0} = 25V$	2SB642 $-V_{CB0} = 60V$ $-V_{CE0} = 50V$	CT-160, DT-D1000G, BT-S700N, BT-S701N, BT-S702N
2SD638 $V_{CB0} = 30V$ $V_{CE0} = 25V$	2SD639 $V_{CB0} = 60V$ $V_{CE0} = 50V$	CT-1010M, BT-S700N, BT-S701N, BT-S702N
2SD636 $V_{CB0} = 30V$ $V_{CE0} = 25V$	2SD637 $V_{CB0} = 60V$ $V_{CE0} = 50V$	CT-1010M, CT-160, DT-D1000G, BT-S700N, BT-S701N BT-S702N, FT-H900T

Note: Differences between original and substitute transistors are only V_{CB0} and V_{CE0} (breakdowns voltage).

Substitute transistors have higher V_{CB0} and V_{CE0} than original ones. Thus there is no problem.

Important: Reverse substitution cannot be done. I.E. if 2SC1384 is used in an original application, do not try to substitute with 2SC1383.

Panasonic

Matsushita Engineering and
Service Company
50 Meadowland Parkway,
Secaucus, New Jersey 07094

Panasonic Hawaii Inc.
91-238 Kauhū St. Ewa Beach
P.O. Box 774
Honolulu, Hawaii 96808-0774

Panasonic Sales Company,
Division of Matsushita Electric
of Puerto Rico, Inc.
Ave. 65 De Infantería, KM 9.7
Victoria Industrial Park
Carolina, Puerto Rico 00630

