

MODEL NO. RIB 1010

TEXAS INSTRUMENTS

BLACK CASSETTE RIBBON

BLACK CASSETTE RIBBON TO FIT
INSIDE YOUR TEXAS INSTRUMENTS
PRINTER 80

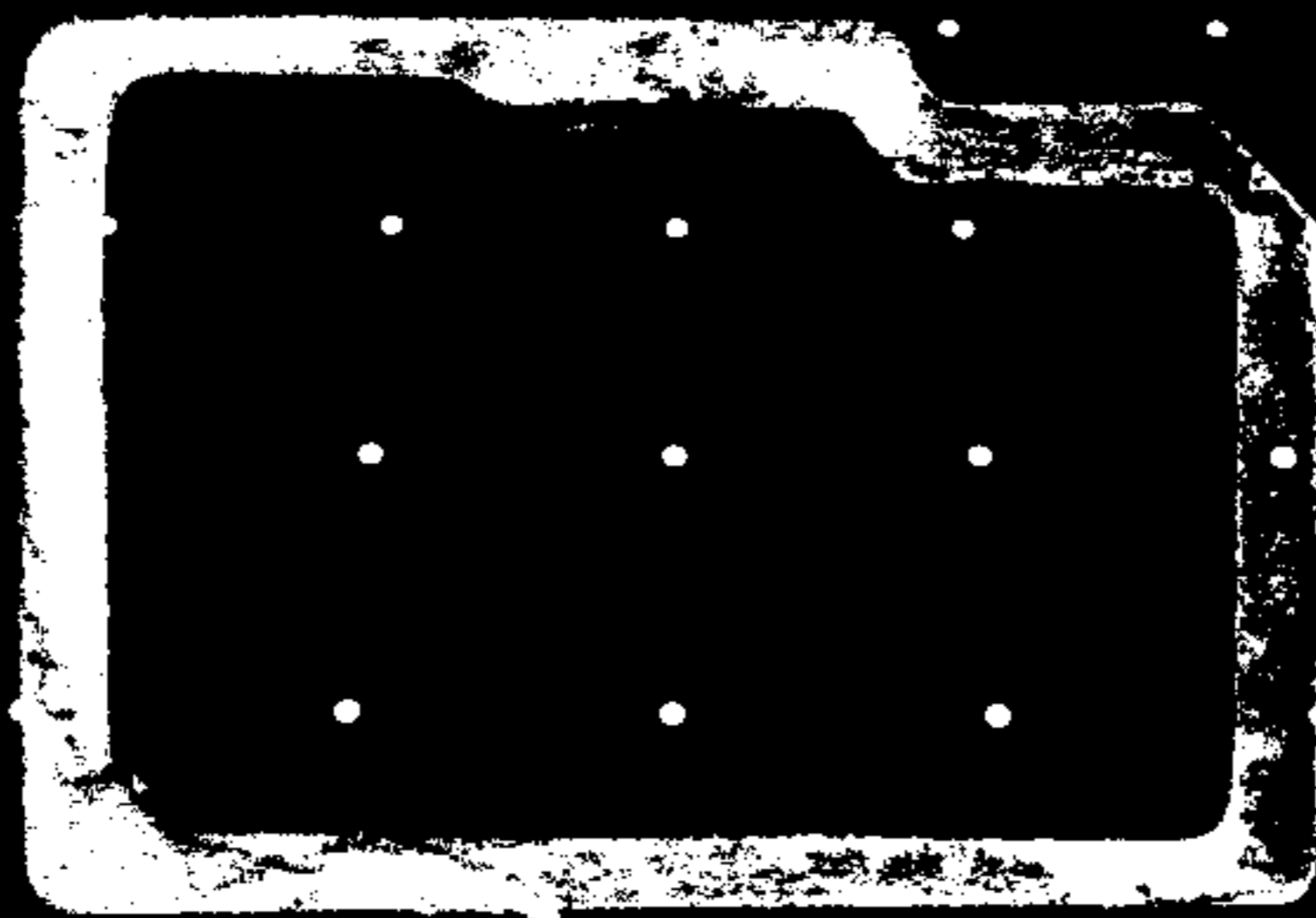

FOR USE WITH THE TEXAS INSTRUMENTS HEX-BUS™ PRINTER 80

Inserting A Cassette Ribbon:

1. Turn off the Printer (unless a file is currently open for the Printer).
2. Release the cassette ribbon as indicated.
3. Remove the used cassette ribbon.
4. Remove the green tab on the new cassette ribbon.
5. Insert the new cassette as indicated.
6. Turn the wheel on the cassette in a counterclockwise direction to tighten the ribbon.
7. Return the release lever to its original position.

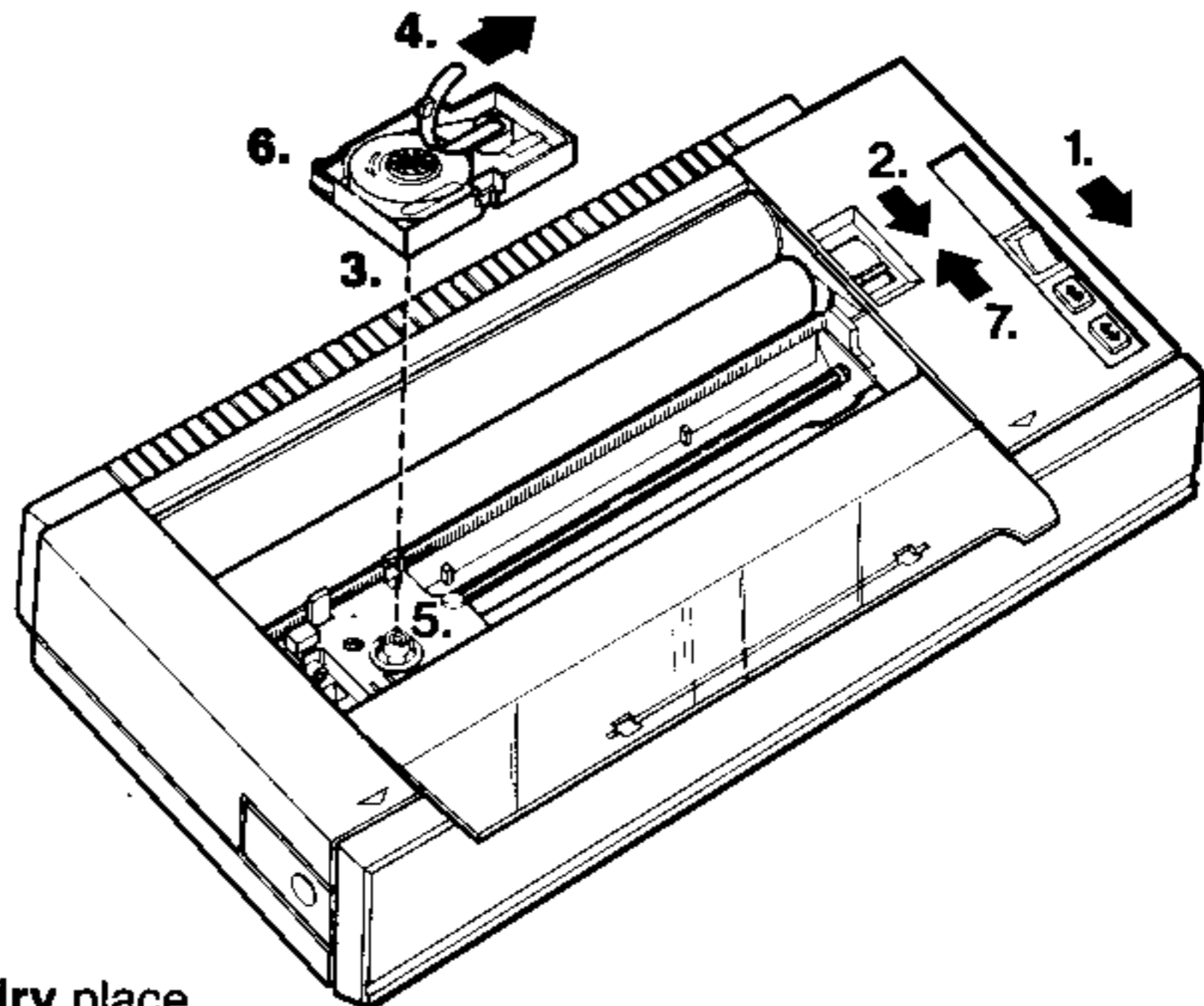

WARNING: Store the cassette ribbon in a **cool, dry place.**

Storage above +60°C will damage ribbon.

CAUTION

The electronic components of the computer and peripherals can be damaged by discharges of static electricity. To remove static, touch a metal object such as a doorknob or desk lamp before handling the devices. Avoid touching the connector contacts.



TEXAS INSTRUMENTS
INCORPORATED
Dallas Texas

Assembled in Japan. Copyright © 1983, Texas Instruments Incorporated.

1057279-1